



Engineered Wood

CONSTRUCTION GUIDE



©2011 APA – THE ENGINEERED WOOD ASSOCIATION • ALL RIGHTS RESERVED • ANY COPYING, MODIFICATION, DISTRIBUTION OR OTHER USE OF THIS PUBLICATION OTHER THAN AS EXPRESSLY AUTHORIZED BY APA IS PROHIBITED BY THE U.S. COPYRIGHT LAWS.

WOOD

The Natural Choice



Engineered wood products are a good choice for the environment. They are manufactured for years of trouble-free, dependable use. They help reduce waste by decreasing disposal costs and product damage. Wood is a renewable resource that is easily manufactured into a variety of viable products.

A few facts about wood.

- **We're growing more wood every day.** Forests fully cover one-third of the United States' and one-half of Canada's land mass. American landowners plant more than two billion trees every year. In addition, millions of trees seed naturally. The forest products industry, which comprises about 15 percent of forestland ownership, is responsible for 41 percent of replanted forest acreage. That works out to more than one billion trees a year, or about three million trees planted every day. This high rate of replanting accounts for the fact that each year, 27 percent more timber is grown than is harvested. Canada's replanting record shows a fourfold increase in the number of trees planted between 1975 and 1990.



- **Life Cycle Assessment shows wood is the greenest building product.** A 2004 Consortium for Research on Renewable Industrial Materials (CORRIM) study gave scientific validation to the strength of wood as a green building product. In examining building products' life cycles – from extraction of the raw material to demolition of the building at the end of its long lifespan – CORRIM found that wood was better for the environment than steel or concrete in terms of embodied energy, global warming potential, air emissions, water emissions and solid waste production. For the complete details of the report, visit www.CORRIM.org.

- **Manufacturing wood is energy efficient.** Wood products made up 47 percent of all industrial raw materials manufactured in the United States, yet consumed only 4 percent of the energy needed to manufacture all industrial raw materials, according to a 1987 study.

Material	Percent of Production	Percent of Energy Use
Wood	47	4
Steel	23	48
Aluminum	2	8



- **Good news for a healthy planet.** For every ton of wood grown, a young forest produces 1.07 tons of oxygen and absorbs 1.47 tons of carbon dioxide.

Wood: It's the natural choice for the environment, for design and for strong, lasting construction.



NOTICE:
The recommendations in this guide apply only to products that bear the APA trademark. Only products bearing the APA trademark are subject to the Association's quality auditing program.

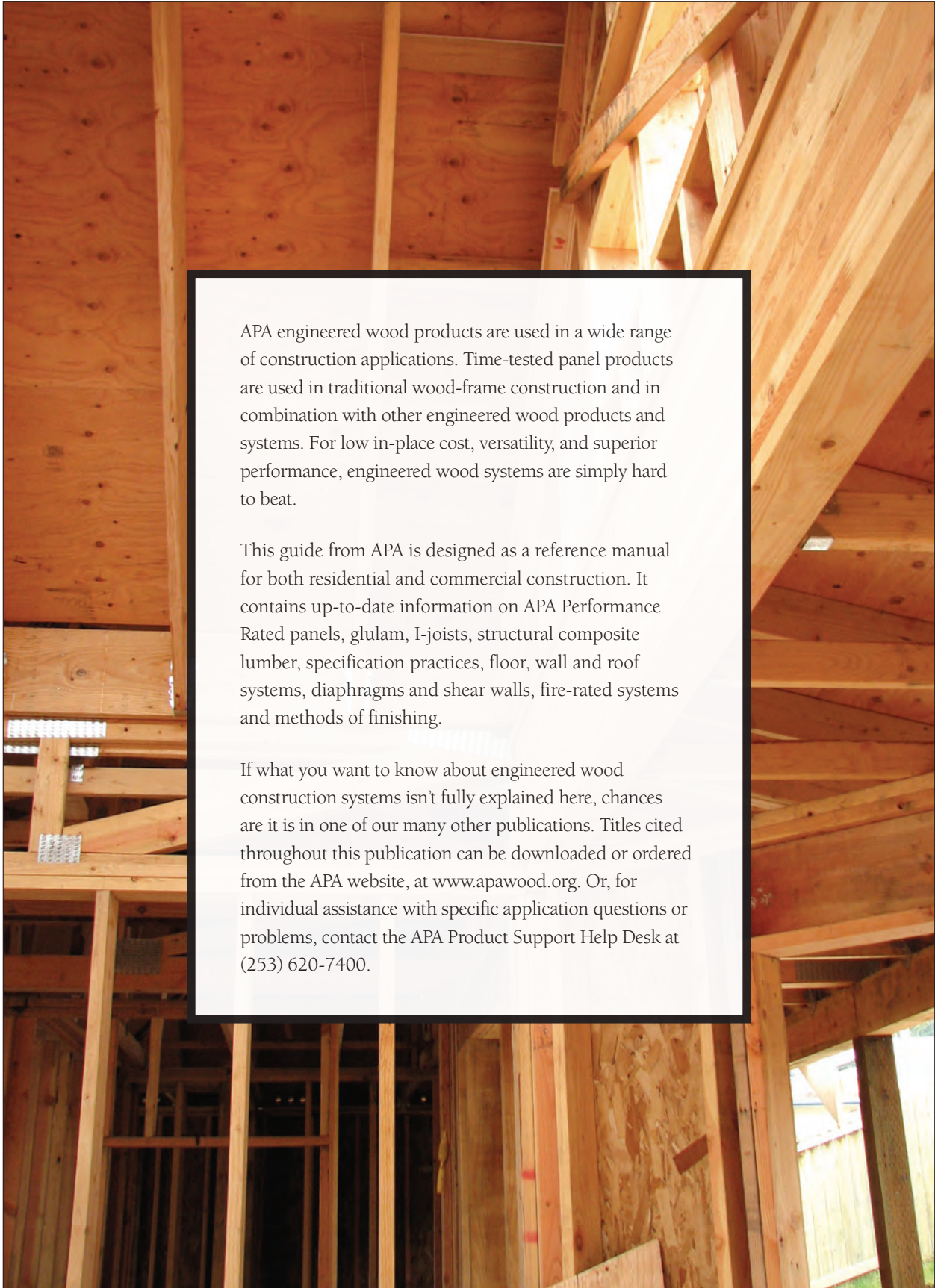

APA engineered wood products are used in a wide range of construction applications. Time-tested panel products are used in traditional wood-frame construction and in combination with other engineered wood products and systems. For low in-place cost, versatility, and superior performance, engineered wood systems are simply hard to beat.

This guide from APA is designed as a reference manual for both residential and commercial construction. It contains up-to-date information on APA Performance Rated panels, glulam, I-joists, structural composite lumber, specification practices, floor, wall and roof systems, diaphragms and shear walls, fire-rated systems and methods of finishing.

If what you want to know about engineered wood construction systems isn't fully explained here, chances are it is in one of our many other publications. Titles cited throughout this publication can be downloaded or ordered from the APA website, at www.apawood.org. Or, for individual assistance with specific application questions or problems, contact the APA Product Support Help Desk at (253) 620-7400.

CONTENTS

GUIDE TO ENGINEERED WOOD PRODUCTS	5	APA Plywood Underlayment	38
Panel Selection and Specification	5	Hardwood Flooring Over APA Panel Subfloors	40
Manufacturing and Performance Standards	5	Ceramic Tile Over APA Plywood Floors	40
Grade Designations	6	APA Panel Stair Treads and Risers	43
Sanded, Unsanded and Touch-Sanded Panels	6	Heavy Duty Plywood Floors	43
Thickness Designation and Performance Category	6	WALL CONSTRUCTION	45
Bond Classification	7	APA Sturd-I-Wall®	45
Moisture Exposure Recommendations	12	Siding Fasteners	48
Group Number	12	Wood Structural Panel Sheathing as a Nail Base for Siding	48
Span Ratings	12	APA Panel Wall Sheathing	52
How to Order APA Panels	13	APA Sheathing Under Stucco	53
Grade Availability	14	Siding Joint Details	53
Nail Sizes	14	APA Rated Siding Patterns and Grades	55
Metric Conversions	14	Finishing Plywood for Exterior Exposure	55
Panel Storage and Handling	15	Interior Paneling	57
Panel Specification Guide	16	Panel Backing	58
Glulam Selection and Specification	20	Wood Structural Panel Wall Bracing and Shear Walls	58
Balanced and Unbalanced Beams	20	Wall Bracing	60
Allowable Design Properties	20	Shear Walls	60
Sizes	21	ROOF CONSTRUCTION	61
Appearance Classification	22	APA Panel Roof Sheathing	61
Section Properties and Capacities	22	Preframed Roof Panels	63
Camber	22	Long Span Systems	65
Trademarks and Acceptances	23	Plywood Under Special Coatings	66
Glulam Beam Storage and Handling	24	APA Panel Soffits	66
Glulam Specification Guide	25	APA Panel Roof Diaphragms	68
I-Joist Selection and Specification	26	BUILDING REQUIREMENTS AND RELATED PANEL SYSTEMS	70
APA PRI-400	27	Fire-resistant Construction	70
Residential Floor Spans	27	Wind-resistive Roofs	76
I-Joist Storage and Handling	28	Noise Transmission Control	77
APA Performance Rated I-Joist Specification Guide	28	Energy Conservation	78
Structural Composite Lumber Selection and Specification	29	Condensation: Its Cause and Control	79
Laminated Veneer Lumber (LVL)	29	Thermal Resistance of Wood Structural Panels	80
Parallel Strand Lumber (PSL)	29	Related Panel Systems	81
Laminated Strand Lumber (LSL)	29	The Permanent Wood Foundation	81
Oriented Strand Lumber (OSL)	29	Plywood for Outdoor Decks	81
Allowable Strength Properties	30	Plywood for Concrete Forming	81
Structural Composite Lumber (SCL) Specification Guide	30	Structural Insulated Panels	82
FLOOR CONSTRUCTION	31	APA Panels Over Metal Framing	82
APA Rated Sturd-I-Floor®	31	APA Panel Systems Over Concrete Slabs	82
Sturd-I-Floor 32 oc and 48 oc	34	Special Floor Surfacing	83
APA Performance Rated Rim Board®	35	ADDITIONAL INFORMATION	83
The APA Glued Floor System	35	About APA – The Engineered Wood Association	83
APA Panel Subflooring	37		
Lightweight Concrete Over APA Panels	38		



GUIDE TO ENGINEERED WOOD PRODUCTS

The evolution of engineered wood products has greatly expanded building options and methods in all forms of residential and commercial construction. The product section of this APA guide provides product information and specification recommendations for several of the most common engineered wood products – plywood, oriented strand board, glulam, and I-joists. Other engineered wood products that are often used in the construction systems described in this guide include Rim Board® and structural composite lumber (SCL).

“Engineered wood” describes wood products that are engineered for structural applications. Plywood has been used since the 1940s, and is considered by many to be the original engineered wood product. All glued engineered wood products are made by combining wood strands, veneers, lumber or other wood fiber with adhesive to form a larger composite structural unit. They are designed and manufactured to maximize the natural strength and stiffness characteristics of wood by optimally orienting the wood veneers, strands or laminations and by combining wood with durable adhesives.

PANEL SELECTION AND SPECIFICATION

Manufacturing and Performance Standards

Panels for construction and industrial applications can be manufactured in a variety of ways – as plywood (cross-laminated wood veneer), oriented strand board (OSB) or other wood-based panel products.

Some plywood panels are manufactured under the detailed manufacturing specifications or under the performance testing provisions of [Voluntary Product Standard PS 1-09 for Structural Plywood](#), developed cooperatively by the plywood industry, user groups and the U.S. Department of Commerce. Other plywood panels, however, as well as composite and OSB panels, are manufactured under the provisions of [APA PRP-108, Performance Standards and Qualification Policy for Structural-Use Panels](#), or under [Voluntary Product Standard PS 2-10, Performance Standard for Wood-Based Structural-Use Panels](#), that establish performance criteria for specific designated construction applications.

These APA Performance Rated Panels are easy to use and specify because the recommended end use and maximum support spacings are clearly indicated in the APA trademark located on the panel. By broadening the range of panel configurations and compositions,

TABLE 1

VENEER GRADES

A	Smooth, paintable. Not more than 18 neatly made repairs, boat, sled, or router type, and parallel to grain, permitted. Wood or synthetic repairs permitted. May be used for natural finish in less demanding applications.
B	Solid surface. Shims, sled or router repairs, and tight knots to 1 inch across grain permitted. Wood or synthetic repairs permitted. Some minor splits permitted.
C	Improved C veneer with splits limited to 1/8 inch width and knotholes or other open defects limited to 1/4 x 1/2 inch.
Plugged C	Wood or synthetic repairs permitted. Admits some broken grain.
C	Tight knots to 1-1/2 inches. Knotholes to 1 inch across grain and some to 1-1/2 inches if total width of knots and knotholes is within specified limits. Synthetic or wood repairs. Discoloration and sanding defects that do not impair strength permitted. Limited splits allowed. Stitching permitted.
D	Knots and knotholes to 2-1/2 inch width across grain and 1/2 inch larger within specified limits. Limited splits are permitted. Stitching permitted. Limited to Exposure 1.

APA Performance Rated Panels allow more efficient use of raw materials. APA PRP-108 Performance Standards are recognized through **ESR-2586** by the **International Code Council Evaluation Service (ICC-ES, www.icc-es.org)** and **HUD**^(a). PRP-108, PS 1 and/or the PS 2 grade conformance where applicable are given in the lower portion of the APA trademark. Plywood panels manufactured to these performance standards, depending on bond classification, veneer species and Performance Category, etc., are in many instances identical to panel grades as defined in Product Standard PS 1-09.

Typical APA panel trademarks are illustrated and explained at right.

Grade Designations

Structural panel grades are generally identified in terms of the veneer grade used on the face and back of the panel (e.g., A-B, B-C, etc.), or by a name suggesting the panel's intended end use (e.g., APA RATED SHEATHING, APA RATED STURD-I-FLOOR, etc.). See **Tables 2–4**.

Veneer grades define veneer appearance in terms of natural unrepaired growth characteristics and allowable number and size of repairs that may be made during manufacture. See Table 1. The highest quality veneer grade commonly available is A. The minimum grade of veneer permitted in Exterior plywood is C-grade. D-grade veneer is only permitted to be used in panels intended for applications protected from long-term exposure to weather.

Sanded, Unsanded and Touch-Sanded Panels

Panels with B-grade or better veneer faces are always sanded smooth in manufacture to fulfill the requirements of their intended end use – applications such as cabinets, shelving, furniture, built-ins, etc. APA RATED SHEATHING panels are unsanded since a smooth surface is not a requirement of their intended end use. Still other panels – APA UNDERLAYMENT, APA RATED STURD-I-FLOOR, APA C-D PLUGGED, and APA C-C PLUGGED – require only touch sanding for “sizing” to make the panel thickness more uniform.

Unsanded and touch-sanded panels, and panels with B-grade or better veneer on one side only, usually carry the APA trademark on the panel back. Panels with both sides of B-grade or better veneer, or with special overlaid surfaces (such as HIGH DENSITY OVERLAY) usually carry the APA trademark on the panel edge.

Thickness Designation and Performance Category

Up until 2008, the thickness of structural panels like plywood and OSB was designated and labeled by the panel's nominal thickness which was subject to a plus and minus tolerance specified in the Voluntary Product Standards PS 1 and PS 2. The tolerance on unsanded panel types used in construction is plus or minus 1/32 inch of the designated thickness. The tolerance on sanded grades of plywood is plus or minus 1/64 inch of the designated thickness. These thickness tolerances were applied at the time of manufacturing or at a standard dry condition since it is recognized that actual panel thickness may naturally change due to changes in panel moisture conditions.

Model codes, technical recommendations, designs and specifications have been based upon the use of these panel nominal thicknesses. However, packaging and labeling regulations adopted as state and local law specify that labeling of dimensions comply with standards developed by the National Conference on Weights and Measures. These

The diagram illustrates three APA panel trademarks with numbered callouts (1-16) pointing to various parts of the label. The first trademark is for a STURD-I-FLOOR panel (240c), the second is for SHEATHING (48/24), and the third is for SIDING (160c). The callouts are defined in the legend below.

- 1 Panel grade
- 2 Span Rating
- 3 Tongue-and-groove
- 4 Siding face grade
- 5 Species group number
- 6 Bond classification
- 7 Decimal thickness designation (this value is generally at or near the lower tolerance specified in PS 1 or PS 2)
- 8 Mill number
- 9 Product Standard
- 10 APA's performance rated panel standard
- 11 HUD recognition
- 12 Performance Category
- 13 Panel grade, Canadian standard
- 14 Panel mark – Rating and end-use designation per the Canadian standard
- 15 Canadian performance rated panel standard
- 16 Panel face grain orientation indicator

(a) HUD recognition of wood-based APA Performance Rated Panels is contained in *Use of Materials Bulletin UM-40*.

regulations require dimensional labeling that is incompatible with the thickness tolerances specified in PS 1 and PS 2. To jointly comply with these regulations while maintaining the specifications within model codes and other existing specifications used in the construction industry, structural panels are now labeled with both a Performance Category and a decimal thickness designation. The decimal thickness designation is generally at or near the lower thickness tolerance permitted in PS 1 and PS 2.

The term “Performance Category” is defined within PS 1 and PS 2 as **a panel designation related to the panel thickness range that is linked to the nominal panel thickness designations used in the International Building Code (IBC) and International Residential Code (IRC). For purposes of labeling, abbreviations PERF CAT, CAT, or Category are permitted within the panel grade mark.** The 2012 International Building Code (IBC) and International Residential Code (IRC) state that **the Performance Category value shall be used as the “nominal panel thickness” or “panel thickness” whenever referenced in the code.**

This publication widely uses the Performance Category as the panel designation. There are some places where traditional nominal thickness designations are used, and in those instances, they should be considered as equivalent to the Performance Category.

Bond Classification

APA trademarked panels may be produced in two bond classifications – Exterior and Exposure 1. The bond classification relates to moisture resistance of the glue bond. Since aesthetic (nonstructural) attributes of panels may be compromised to some degree by exposure to weather, installation recommendations in this publication are designed to provide optimum overall performance.

Bond classification of the panel does not relate to fungal decay resistance of the panel. Fungal decay of wood products may occur when the moisture content exceeds 20 percent for an extended period. See *APA Technical Note, Controlling Decay in Wood Construction, Form R495*, for a discussion of fungal decay. Prevention of fungal decay is a function of proper design, material specification, construction and maintenance of the structure. While this publication includes many of the applicable provisions, reference to local building codes and other design documents is also necessary.

Exterior panels have bonds capable of withstanding repeated wetting and redrying or long-term exposure to weather or other conditions of similar severity.

Exposure 1 panels are suitable for uses **not** involving long-term exposure to weather. Panels classified as Exposure 1 are intended to resist the effects of moisture due to construction delays, or other conditions of similar severity. Exposure 1 panels may also be used when exposure to the outdoors is on the under-side only, such as at roof overhangs, although appearance characteristics of the panel grade should also be considered. Exposure 1 panels are made with the same exterior adhesives used in Exterior panels. However, because other panel compositional factors may affect bond performance, only Exterior panels should be used for long-term exposure to the weather.

C-D Exposure 1 APA Rated Plywood Sheathing, sometimes called “CDX” in the trade, is occasionally mistaken as an Exterior panel and erroneously used in applications for which it does not possess the required resistance to weather. “CDX” should only be used for applications as outlined under Exposure 1 above. For sheathing grade panels that will be exposed long-term to the weather, specify APA Rated Sheathing Exterior (C-C Exterior plywood under PS 1).

Continued on page 12

TABLE 2

**GUIDE TO APA PERFORMANCE RATED PANELS^{(a)(b)}
FOR APPLICATION RECOMMENDATIONS, SEE FOLLOWING PAGES.**

APA RATED SHEATHING
Typical Trademark

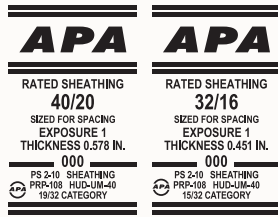

Specially designed for subflooring and wall and roof sheathing. Also good for a broad range of other construction and industrial applications. Can be manufactured as OSB, plywood, or other wood-based panel. BOND CLASSIFICATIONS: Exterior, Exposure 1. COMMON PERFORMANCE CATEGORIES: 3/8, 7/16, 15/32, 1/2, 19/32, 5/8, 23/32, 3/4.

APA STRUCTURAL I
RATED SHEATHING^(c)
Typical Trademark

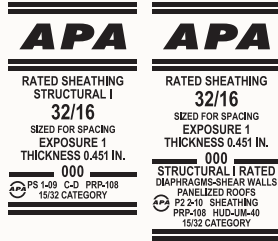

Unsanded grade for use where shear and cross-panel strength properties are of maximum importance, such as panelized roofs and diaphragms. Can be manufactured as OSB, plywood, or other wood-based panel. BOND CLASSIFICATIONS: Exterior, Exposure 1. COMMON PERFORMANCE CATEGORIES: 3/8, 7/16, 15/32, 1/2, 19/32, 5/8, 23/32, 3/4.

APA RATED
STURD-I-FLOOR
Typical Trademark

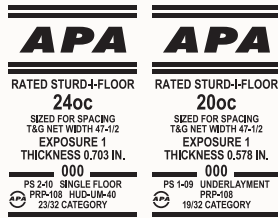

Specially designed as combination subfloor-underlayment. Provides smooth surface for application of carpet and pad and possesses high concentrated and impact load resistance. Can be manufactured as OSB, plywood, or other wood-based panel. Available square edge or tongue-and-groove. BOND CLASSIFICATIONS: Exterior, Exposure 1. COMMON PERFORMANCE CATEGORIES: 19/32, 5/8, 23/32, 3/4, 1, 1-1/8.

APA RATED SIDING
Typical Trademark

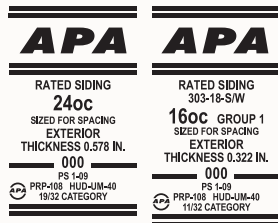

For exterior siding, fencing, etc. Can be manufactured as plywood, as other wood-based panel or as an overlaid OSB. Both panel and lap siding available. Special surface treatment such as V-groove, channel groove, deep groove (such as APA Texture 1-11), brushed, rough sawn and overlaid (MDO) with smooth- or texture-embossed face. Span Rating (stud spacing for siding qualified for APA Sturd-I-Wall applications) and face grade classification (for veneer-faced siding) indicated in trademark. BOND CLASSIFICATION: Exterior. COMMON PERFORMANCE CATEGORIES: 11/32, 3/8, 7/16, 15/32, 1/2, 19/32, 5/8.

APA RATED SHEATHING – WALL
Typical Trademark

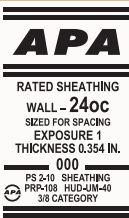

Specially designed for wall sheathing. Not intended for roof or floor sheathing. Can be manufactured as OSB, plywood, or other wood-based panel. BOND CLASSIFICATION: Exposure 1. COMMON PERFORMANCE CATEGORIES: 3/8, 7/16, 15/32.

(a) Specific grades, Performance Categories and bond classifications may be in limited supply in some areas. Check with your supplier before specifying.

(b) Specify Performance Rated Panels by Performance Category and Span Rating. Span Ratings are based on panel strength and stiffness. Since these properties are a function of panel composition and configuration as well as thickness, the same Span Rating may appear on panels of different Performance Categories. Conversely, panels of the same Performance Category may be marked with different Span Ratings.

(c) For some Structural I plywood panel constructions, the plies are special improved grades. Panels marked PS 1 are limited to Group 1 species. Other panels marked Structural I Rated qualify through special performance testing.

TABLE 3

**GUIDE TO APA SANDED AND TOUCH-SANDED PLYWOOD PANELS^{(a)(b)(c)}
FOR APPLICATION RECOMMENDATIONS, SEE FOLLOWING PAGES.**

<p>APA A-A Typical Trademark (mark on panel edge)</p> <p style="border: 1px solid black; padding: 2px;">A-A • G-1 • EXT • 0.734 IN. • APA • 000 • PS 1-09 • 3/4 CAT</p>	<p>Use where appearance of both sides is important for interior applications such as built-ins, cabinets, furniture, partitions; and exterior applications such as fences, signs, boats, shipping containers, tanks, ducts, etc. Smooth surfaces suitable for painting. BOND CLASSIFICATIONS: Exposure 1, Exterior. COMMON PERFORMANCE CATEGORIES: 1/4, 11/32, 3/8, 15/32, 1/2, 19/32, 5/8, 23/32, 3/4.</p>
<p>APA A-B Typical Trademark (mark on panel edge)</p> <p style="border: 1px solid black; padding: 2px;">A-B • G-1 • EXT • 0.234 IN. • APA • 000 • PS 1-09 • 1/4 CAT</p>	<p>For use where appearance of one side is less important but where two solid surfaces are necessary. BOND CLASSIFICATIONS: Exposure 1, Exterior. COMMON PERFORMANCE CATEGORIES: 1/4, 11/32, 3/8, 15/32, 1/2, 19/32, 5/8, 23/32, 3/4.</p>
<p>APA A-C Typical Trademark</p>	<p>For use where appearance of only one side is important in exterior or interior applications, such as soffits, fences, farm buildings, etc.^(d) BOND CLASSIFICATION: Exterior. COMMON PERFORMANCE CATEGORIES: 1/4, 11/32, 3/8, 15/32, 1/2, 19/32, 5/8, 23/32, 3/4.</p>
<p>APA A-D Typical Trademark</p>	<p>For use where appearance of only one side is important in interior applications, such as paneling, built-ins, shelving, partitions, flow racks, etc.^(d) BOND CLASSIFICATION: Exposure 1. COMMON PERFORMANCE CATEGORIES: 1/4, 11/32, 3/8, 15/32, 1/2, 19/32, 5/8, 23/32, 3/4.</p>
<p>APA B-B Typical Trademark (mark on panel edge)</p> <p style="border: 1px solid black; padding: 2px;">B-B • G-2 • EXT • 0.578 IN. • APA • 000 • PS 1-09 • 19/32 CAT</p>	<p>Utility panels with two solid sides. BOND CLASSIFICATIONS: Exposure 1, Exterior. COMMON PERFORMANCE CATEGORIES: 1/4, 11/32, 3/8, 15/32, 1/2, 19/32, 5/8, 23/32, 3/4.</p>
<p>APA B-C Typical Trademark</p>	<p>Utility panel for farm service and work buildings, boxcar and truck linings, containers, tanks, agricultural equipment, as a base for exterior coatings and other exterior uses or applications subject to high or continuous moisture.^(d) BOND CLASSIFICATION: Exterior. COMMON PERFORMANCE CATEGORIES: 1/4, 11/32, 3/8, 15/32, 1/2, 19/32, 5/8, 23/32, 3/4.</p>
<p>APA B-D Typical Trademark</p>	<p>Utility panel for backing, sides of built-ins, industry shelving, slip sheets, separator boards, bins and other interior or protected applications.^(d) BOND CLASSIFICATION: Exposure 1. COMMON PERFORMANCE CATEGORIES: 1/4, 11/32, 3/8, 15/32, 1/2, 19/32, 5/8, 23/32, 3/4.</p>

Continued on next page

TABLE 3 continued

**GUIDE TO APA SANDED AND TOUCH-SANDED PLYWOOD PANELS^{(a)(b)(c)}
FOR APPLICATION RECOMMENDATIONS, SEE FOLLOWING PAGES.**

APA UNDERLAYMENT
Typical Trademark

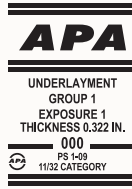

For application over structural subfloor. Provides smooth surface for application of carpet and pad and possesses high concentrated and impact load resistance. For areas to be covered with resilient flooring, specify panels with "sanded face."^(e) BOND CLASSIFICATION: Exposure 1. COMMON PERFORMANCE CATEGORIES^(f): 1/4, 11/32, 3/8, 15/32, 1/2, 19/32, 5/8, 23/32, 3/4.

APA C-C PLUGGED^(g)
Typical Trademark



For use as an underlayment over structural subfloor, refrigerated or controlled atmosphere storage rooms, pallet fruit bins, tanks, boxcar and truck floors and linings, open soffits, and other similar applications where continuous or severe moisture may be present. Provides smooth surface for application of carpet and pad and possesses high concentrated and impact load resistance. For areas to be covered with resilient flooring, specify panels with "sanded face."^(e) BOND CLASSIFICATION: Exterior. COMMON PERFORMANCE CATEGORIES^(f): 11/32, 3/8, 15/32, 1/2, 19/32, 5/8, 23/32, 3/4.

APA C-D PLUGGED
Typical Trademark

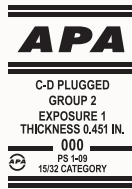

For open soffits, built-ins, cable reels, separator boards and other interior or protected applications. Not a substitute for Underlayment or APA Rated Sturd-I-Floor as it lacks their puncture resistance. BOND CLASSIFICATION: Exposure 1. COMMON PERFORMANCE CATEGORIES: 3/8, 15/32, 1/2, 19/32, 5/8, 23/32, 3/4.

- (a) Specific plywood grades, Performance Categories and bond classifications may be in limited supply in some areas. Check with your supplier before specifying.
- (b) Sanded Exterior plywood panels, C-C Plugged, C-D Plugged and Underlayment grades can also be manufactured in Structural I (all plies limited to Group 1 species).
- (c) Some manufacturers also produce plywood panels with premium N-grade veneer on one or both faces. Available only by special order. Check with the manufacturer. For a description of N-grade veneer, refer to the APA publication *Sanded Plywood*, Form K435.

- (d) For nonstructural floor underlayment, or other applications requiring improved inner ply construction, specify panels marked either "plugged inner plies" (may also be designated "plugged crossbands under face" or "plugged crossbands" or "core"); or "meets underlayment requirements."
- (e) Also available in Underlayment A-C or Underlayment B-C grades, marked either "touch sanded" or "sanded face."
- (f) Some panels with Performance Categories of 1/2 and larger are Span Rated and do not contain species group number in trademark.
- (g) Also may be designated APA Underlayment C-C Plugged.

TABLE 4

**GUIDE TO APA SPECIALTY PLYWOOD PANELS^(a)
FOR APPLICATION RECOMMENDATIONS, SEE FOLLOWING PAGES.**

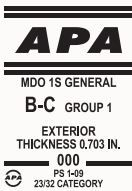
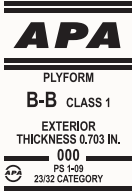
<p>APA Decorative Typical Trademark</p> 	<p>Rough-sawn, brushed, grooved, or striated faces. For paneling, interior accent walls, built-ins, counter facing, exhibit displays. Can also be made by some manufacturers in Exterior for exterior siding, gable ends, fences and other exterior applications. Use recommendations for Exterior panels vary with the particular product. Check with the manufacturer. BOND CLASSIFICATIONS: Exposure 1, Exterior. COMMON PERFORMANCE CATEGORIES: 5/16, 3/8, 1/2, 5/8.</p>
<p>APA High Density Overlay (HDO)^(b) Typical Trademark (mark on panel edge)</p> <p>HDO • INDUSTRIAL • A-A • G2 • EXT • 0.734 IN. • APA • 000 • PS 1-09 • 3/4 CAT</p>	<p>Has a hard opaque resin-fiber overlay on one or both faces. Abrasion resistant. For concrete forms, cabinets, countertops, signs, tanks. Also available with skid-resistant screen-grid surface. HDO is manufactured in two grades: Concrete Form and Industrial. BOND CLASSIFICATION: Exterior. COMMON PERFORMANCE CATEGORIES: 11/32, 3/8, 15/32, 1/2, 19/32, 5/8, 23/32, 3/4.</p>
<p>APA Medium Density Overlay (MDO)^(b) Typical Trademark</p> 	<p>Smooth, opaque, resin-fiber overlay on one or both faces. Ideal base for paint, both indoors and outdoors. For exterior siding, paneling, shelving, exhibit displays, cabinets, concrete forms, signs. MDO is manufactured in two grades: Concrete Form and General. BOND CLASSIFICATION: Exterior. COMMON PERFORMANCE CATEGORIES: 11/32, 3/8, 15/32, 1/2, 19/32, 5/8, 23/32, 3/4.</p>
<p>APA Marine Typical Trademark (mark on panel edge)</p> <p>MARINE • A-A • EXT • 0.609 IN. • APA • 000 • PS 1-09 • 5/8 CAT</p>	<p>Ideal for boat hulls. Made only with Douglas-fir or western larch. Subject to special limitations on core gaps and face repairs. Also available with HDO or MDO faces. BOND CLASSIFICATION: Exterior. COMMON PERFORMANCE CATEGORIES: 1/4, 3/8, 1/2, 5/8, 3/4.</p>
<p>APA Plyform Class I^(b) Typical Trademark</p>  <p>Typical Trademark (mark on panel edge)</p> <p>PLYFORM • B-B • CL I • EXT • 0.734 IN. • APA • 000 • PS 1-09 • 3/4 CAT</p>	<p>Concrete form grades with high reuse factor. Sanded both faces and mill-oiled unless otherwise specified. Special restrictions on species. Also available in HDO or MDO for very smooth concrete finish, and with special overlays. BOND CLASSIFICATION: Exterior. COMMON PERFORMANCE CATEGORIES: 19/32, 5/8, 23/32, 3/4.</p>
<p>APA Plyron Typical Trademark (mark on panel edge)</p> <p>TEMPERED PLYRON • EXT • 0.734 IN. • APA • 000 • 3/4 CAT</p> <p>STANDARD PLYRON • EXP 1 • 0.734 IN. • APA • 000 • 3/4 CAT</p>	<p>Hardboard face on both sides. Faces tempered, untempered, smooth or screened. For countertops, shelving, cabinet doors, flooring. BOND CLASSIFICATIONS: Exposure 1, Exterior. COMMON PERFORMANCE CATEGORIES: 1/2, 5/8, 3/4.</p>

(a) Specific plywood grades, Performance Category and bond classifications may be in limited supply in some areas. Check with your supplier before specifying.

(b) Can also be manufactured in Structural I (all plies limited to Group 1 species).

Moisture Exposure Recommendations

APA recommendations take into account bond classification as well as other panel compositional factors that may affect bond or panel performance.

The table at right provides guidance regarding moisture content and recommended bond classification.

By far, most wood structural panels are used in interior or dry-use moisture conditions, where in-service moisture content will be less than 16 percent over the service life. In North America the typical in-service equilibrium moisture content is in the 8 percent to 12 percent range for wood structural panels.

Occasionally, however, an application will subject panels to higher long-term moisture conditions, such as in locations where relative humidity is 90 percent or more for long periods of time.

In-Service Moisture Content	End-Use Moisture Conditions	Recommended Bond Classification	Design Moisture Conditions ^(a)
Less than 16%	Dry uses	Exposure 1 or Exterior	Dry
16% to 19%	Humid interior or protected uses	Exposure 1 or Exterior	Wet
	Long-term exposure to weather	Exterior	Wet
Greater than 19%	Other very humid or wet uses	Exterior ^(b)	Wet
	Ground contact	Exterior ^(b)	Wet

(a) Contact APA for specific design provisions.
 (b) Recommend pressure treatment.

Group Number

Plywood can be manufactured from over 70 species of wood. These species are divided on the basis of strength and stiffness into five Groups under Voluntary Product Standard PS 1. Strongest species are in Group 1; the next strongest in Group 2, and so on. The Group number that appears in the trademark on some APA trademarked panels – primarily sanded grades – is based on the species used for face and back veneers or upon equivalent strength testing of the panel. Where face and back veneers are not from the same species Group, the higher Group number is used, except for sanded panels 3/8 inch thick or less and Decorative panels of any thickness. These are identified by face species because they are chosen primarily for appearance and used in applications where structural integrity is not critical. Sanded panels greater than 3/8 inch are identified by face species if C or D grade backs are at least 1/8 inch and are no more than one species group number larger. Some species are used widely in plywood manufacture; others rarely. Check local availability if a particular species is desired.

Span Ratings

APA RATED SHEATHING, APA RATED STURD-I-FLOOR and APA RATED SIDING carry numbers in their trademarks called Span Ratings. These denote the maximum recommended center-to-center spacing in inches of supports over which the panels should be placed in normal code-conforming construction. Except for APA RATED SIDING panels, the Span Rating applies when the long panel dimension or strength axis is across supports, unless the strength axis is otherwise identified on the panel. The Span Rating of APA RATED SIDING panels applies when panels are installed vertically (parallel to studs).

The Span Rating on APA RATED SHEATHING panels appears as two numbers separated by a slash, such as 32/16, 48/24, etc.^(a) The left-hand number denotes the maximum recommended spacing of supports when the panel is used for roof sheathing with the **strength axis of the panel across three or more supports (two or more spans)**. The right-hand number denotes the maximum recommended spacing of supports when the panel is used for subflooring with the **strength axis of the panel across three or more supports (two or more spans)**. A panel marked 32/16, for example, may be used for roof decking over supports up to 32 inches on center or for subflooring over supports up to 16 inches on center. When APA RATED SHEATHING is used for roof decking and subfloor applications see Tables 30 and 12 respectively, for recommended live-load capacities.

The Span Rating on APA RATED STURD-I-FLOOR and APA RATED SIDING panels appears as a single number. APA RATED STURD-I-FLOOR panels are designed specifically for single-floor (combined subfloor-underlayment) applications under carpet and pad and are manufactured with Span Ratings of 16, 20^(b), 24, 32 and 48. The Span Ratings for APA RATED STURD-I-FLOOR panels, like those for APA RATED SHEATHING, are based on application of the panel with the **strength axis of the panel across three or more supports (two or more spans)**. When APA RATED STURD-I-FLOOR is used for single-floor applications see Table 12 for recommended live load capacities. APA RATED STURD-I-FLOOR may be also used in roof decking applications. For such applications, see Table 30 for recommended roof live load capacities.

APA RATED SIDING is available with Span Ratings of 16 and 24 inches. Span-rated panels and lap siding may be used direct to studs or over nonstructural wall sheathing (Sturd-I-Wall construction), or over nailable panel (see Table 22) or lumber sheathing (double wall construction). Panels and lap siding with a Span Rating of 16 inches may be applied direct to studs spaced 16 inches on center. Panels and lap siding bearing a Span Rating of 24 inches may be used direct to studs 24 inches on center. All RATED SIDING panels may be applied horizontally direct to studs 16 or 24 inches on center provided horizontal joints are blocked. When used over structural sheathing, the Span Rating of APA RATED SIDING panels refers to the maximum recommended spacing of vertical rows of fasteners rather than to stud spacing.

For a description of Span Ratings under the Canadian Standard for Construction Sheathing, refer to the *APA Product Guide: Oriented Strand Board, Form W410*.

How to Order APA Panels

Sanded and Touch-Sanded Panels: Designate Performance Category, APA trademark, grade, Group number^(c), bond classification, dimensions, number of pieces. For example:

- 3/4 APA A-A, Group 1, Exterior, 48" x 96", 100 pcs.
- 3/8 APA Underlayment, Group 1, Exposure 1, 48" x 96", 100 pcs.

(Designate "sanded face" if panels are to be used under resilient flooring, or see Table 14 for additional information.)

Performance Rated Panels: Designate Performance Category, APA trademark, grade, Span Rating, bond classification, dimensions, number of pieces. For example:

- 15/32 APA RATED SHEATHING, 32/16, Exposure 1, 48" x 96", 100 pcs.
- 23/32 APA RATED STURD-I-FLOOR 24 oc, Exposure 1, 48"^(d) x 96", 100 pcs. (Note "square edge" or "tongue-and-groove" as desired.)

Rated Sidings: Designate Performance Category, APA trademark, face grade (for APA RATED SIDING-303), Span Rating, texture, pattern, dimensions, number of pieces. For example:

- 19/32 APA RATED SIDING 303-18-W, 16 oc, rough-sawn Texture 1-11[®], grooves 4" o.c., 48" x 96", 100 pcs. (Note manufacturer's trade name if desired.)

Concrete Form: Designate Performance Category, APA trademark, Class, dimensions, number of pieces. For example:

- 5/8 APA PLYFORM Class I, 48" x 96", 100 pcs. (Plyform panels are manufactured only as Exterior panels and are mill-oiled unless otherwise specified.)

(a) Exceptions are APA RATED SHEATHING intended for use as wall sheathing only, and APA RATED WALL BRACING. The trademarks for such panels contain a single number similar to the Span Rating for APA RATED SIDING.

(b) For Span Rating of 20, actual support spacing is 19.2 inches.

(c) Underlayment and C-C Plugged panels Performance Category 1/2 and larger are generally span rated and do not contain species group number in trademark. Designate Span Rating.

(d) Most tongue-and-groove panels are manufactured with a 47-1/2-inch net face width, although manufacturing practices vary. Check with your supplier.

Overlaid Panels: Designate Performance Category, APA trademark, grade, Group number, dimensions, number of pieces. For example:

- 1/2 APA MEDIUM DENSITY OVERLAY (MDO) GENERAL or (APA RATED SIDING 303-OL in the case of overlaid panels produced under the APA RATED SIDING-303 manufacturing specification), Group 1, 48" x 96", 100 pcs. (Any special requirements, such as only one side overlaid, surface texture or weight of surfacing material, should be stated after the standard specification.)

Grade Availability

Some panel grades, Performance Categories, Span Ratings, or species may be difficult to obtain in some areas. Check with your supplier for availability or include an alternate panel in specifications. Standard panel dimensions are 4 feet by 8 feet, although some mills also produce larger panels.

Nail Sizes

Various nail penny sizes are referenced throughout this document. For most cases, the appropriate lengths and wire sizes can be found in Table 5.

Metric Conversions

Metric equivalents of panel thickness and common sizes of wood structural panels are tabulated at right (1 inch = 25.4 millimeters):

TABLE 5

NAIL SIZES (ASTM F1667)

Penny Size (d)	Type	Length (in.)	Wire Diameter (in.)
3d	Ring- or screw-shank	1-1/4	0.099*
	Finish	1-1/2	0.072
4d	Box and Casing	1-1/2	0.080
	Ring- or Screw-shank	1-1/2	0.099*
6d	Finish	2	0.092
	Box and Casing	2	0.099
	Siding	1-7/8	0.106
	Common	2	0.113
	Ring- or Screw-shank	2	0.120*
8d	Finish	2-1/2	0.099
	Box and Casing	2-1/2	0.113
	Siding	2-3/8	0.128
	Common	2-1/2	0.131
10d	Ring- or Screw-shank	2-1/2	0.120* or 0.131*
	Box and Casing	3	0.128
16d	Common	3	0.148
	Box and Casing	3-1/2	0.135
16d	Common	3-1/2	0.162
	Sinker	3-1/4	0.148

*International Staple, Nail and Tool Association (ISANTA) ESR-1539 available at www.icc-es.org

PANEL DIMENSIONS (Width x Length)

ft	Metric Soft Conversion, mm
4 x 8	1220 x 2440
4 x 9	1220 x 2740
4 x 10	1220 x 3050

PANEL THICKNESS

in.	mm
1/4	6.4
5/16	7.9
11/32	8.7
3/8	9.5
7/16	11.1
15/32	11.9
1/2	12.7
19/32	15.1
5/8	15.9
23/32	18.3
3/4	19.1
7/8	22.2
1	25.4
1-3/32	27.8
1-1/8	28.6

Panel Storage and Handling

Like all building materials, APA trademarked structural wood panels should be properly stored, handled and installed to assure superior in-service performance.

Protect the edges and ends of panels, especially tongue-and-groove and shiplap-edged panels. Place panels to be moved by forklift on pallets or bunks when received to avoid damage by fork tines.

Panels to be transported on open truck beds should be covered with standard tarpaulins or “lumber wraps.” For open railcar shipment, use “lumber wrap” to avoid extended weather exposure.

Whenever possible, store panels under a roof, especially if they won't be used soon after received. Keep sanded and other appearance grades away from open doorways, and weight down the top panel in a stack to help avoid any possible warpage from humidity. If moisture absorption is expected, cut steel banding on panel bundles to prevent edge damage.

Panels to be stored outside should be stacked on a level platform supported by 4x4 stringers or other blocking. Never leave panels or the platform in direct contact with the ground. Use at least three full-width supports along the 8-foot length of the panel – one centered and the others 12 to 16 inches from each end.

Cover the stack loosely with plastic sheets or tarps. Anchor the covering at the top of the stack, but keep it open and away from the sides and bottom to assure good ventilation. Tight coverings prevent air circulation and, when exposed to sunlight, create a “greenhouse” effect which may encourage mold formation.

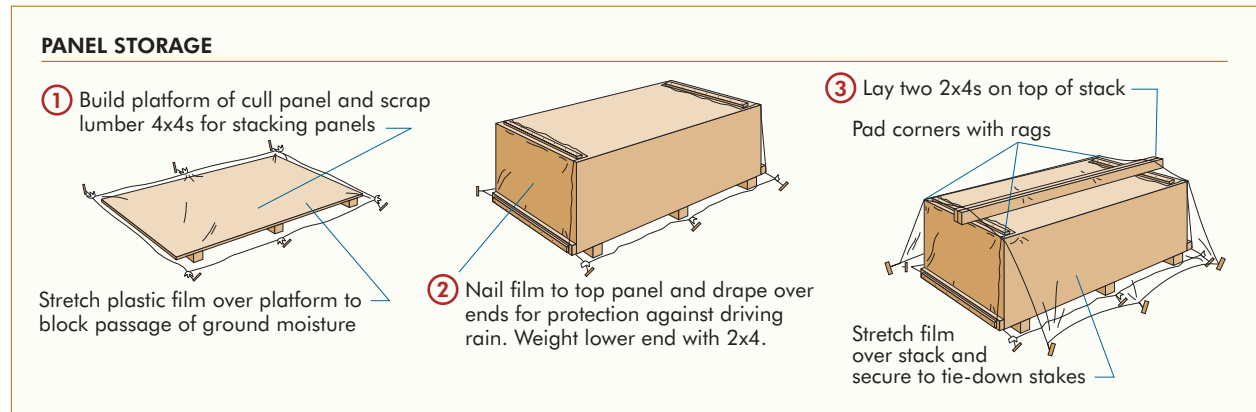

PANEL SPECIFICATION GUIDE⁽¹⁾

CSI* Division 3 – Concrete Formwork

A. Materials

1. Forms – Plywood concrete forms shall be (specify appropriate grade):⁽²⁾

APA PLYFORM CLASS I EXT,

APA HIGH DENSITY OVERLAY CON-
CRETE FORM PLYFORM CLASS I
EXT, or

APA MEDIUM DENSITY OVERLAY
CONCRETE FORM PLYFORM CLASS
I EXT.

Use plywood thickness sufficient to support concrete at temperature and rate poured⁽³⁾; securely brace and shore forms to prevent displacement and to safely support construction loads.

CSI* Division 6 – Wood and Plastics

A. General Provisions

1. Identification Requirements – Each panel shall be identified with the appropriate trademark of APA, and shall meet the requirements of the latest edition of Voluntary Product Standard PS 1, Voluntary Product Standard PS 2 or APA PRP-108 Performance Standards.

2. All panels which have any edge or surface exposed long term to the weather shall be classed Exterior.⁽⁴⁾⁽⁵⁾

3. Panel Performance Category, grade, and Group number or Span Rating shall be at least equal to that shown on the drawings.⁽⁶⁾ Application shall be in accordance with recommendations of APA.⁽⁷⁾

B. Roof Sheathing

1. Panel roof sheathing shall be (specify appropriate grade):

APA RATED SHEATHING EXP 1

APA RATED SHEATHING EXT

APA RATED SHEATHING/CEILING
DECK EXP 1

APA STRUCTURAL I RATED SHEATHING
EXP 1, or

APA STRUCTURAL I RATED SHEATHING
EXT.

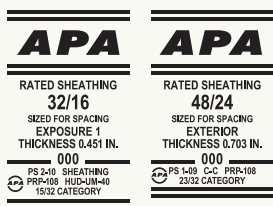

Sheathing exposed long term to weather shall be classed Exterior.⁽⁵⁾

Install with the long dimension or strength axis of the panel across supports, except where noted⁽⁸⁾, and with panel continuous over two or more spans. For pitched roofs, place screened surface or side with skid-resistant coating up, if OSB panels are used. Wear skid-resistant shoes when installing roof sheathing and keep roof deck free of dirt, debris and sawdust during construction. Suitable edge support shall be provided where indicated on drawings (or in recommendations of APA)⁽⁶⁾ by use of panel clips, tongue-and-groove edges, or lumber blocking between joists. Panel end joints shall occur over framing.

Spacing of 1/8" is recommended at all panel ends and edges, unless otherwise indicated by the panel manufacturer.⁽⁹⁾

Unless special nail provisions are required (e.g., high wind areas), nail 6" o.c. along supported panel edges and 12" o.c. at intermediate supports, except that when supports are spaced 48" o.c. or more, space nails 6" o.c. at all supports. Use 8d common nails, except that when panels have a Performance Category of 1-1/8, use 8d ring-shank or 10d common.⁽¹⁰⁾⁽¹¹⁾⁽¹²⁾⁽¹³⁾

Cover roof sheathing as soon as possible with roofing felt or shingle underlayment for protection against excessive moisture prior to roofing application.

C. Floors

1. Subflooring (under structural finish floor such as wood strip or underlayment) – Panel subflooring shall be (specify appropriate grade):

APA RATED SHEATHING EXP 1

APA RATED SHEATHING EXT

APA STRUCTURAL I RATED SHEATHING
EXP 1, or

APA STRUCTURAL I RATED SHEATHING
EXT.

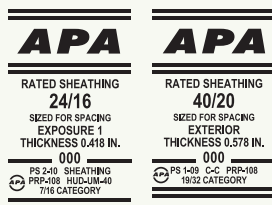

Install with the long dimension or strength axis of the panel across supports and with panel continuous over two or more spans. Panel end joints shall occur over framing. **Spacing of 1/8" is recommended at panel ends and edges,**⁽⁹⁾ unless otherwise indicated by the panel manufacturer.

Nail 6" o.c. along supported panel edges and 12" o.c. at intermediate supports with 6d common nails for panels with a Performance Category of 1/2 or smaller, 8d for greater Performance Categories⁽¹³⁾. Where panels have a Performance Category of 1-1/8 and supports are 48" o.c., nails shall be 8d ring-shank or 10d common and spaced 6" o.c. at all supports.⁽¹⁰⁾⁽¹¹⁾⁽¹²⁾⁽¹³⁾

Sand subfloor joints if necessary to smooth surface prior to installing underlayment or finish flooring.

2. Combined subfloor-underlayment (under carpet and pad)⁽¹⁴⁾ – Combined subfloor-underlayment panels shall be (specify appropriate grade):

APA RATED STURD-I-FLOOR EXP 1, or

APA RATED STURD-I-FLOOR EXT.

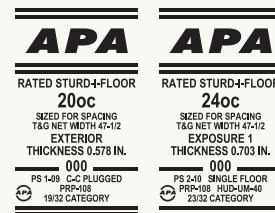

Install with the long dimension or strength axis of the panel across supports and with panel continuous over two or more spans. Panel edges shall be tongue-and-groove or supported on 2-inch lumber blocking installed between joists. Protect against damage until finish floor is installed.

Stagger panel end joints. Panel end joints shall occur over framing. **Spacing of 1/8" is recommended at panel ends and edges,** unless otherwise indicated by the panel manufacturer.⁽⁹⁾

For nailed floors, nail panels 6" o.c. at supported panel edges and 12" o.c. at intermediate supports, except that when supports are spaced 48" o.c., space nails 6" o.c. at all supports. Use 6d ring- or screw-shank nails for panels with a Performance Category of 3/4 and smaller, and 8d for thicker panels.⁽¹³⁾ With

*Construction Specifications Institute
Notes to Panel Specification Guide on page

Performance Category 1-1/8 panels, 10d common nails may be used if supports are well seasoned.⁽¹⁰⁾⁽¹¹⁾⁽¹²⁾⁽¹³⁾

Fill and thoroughly sand edge joints.⁽¹⁵⁾ Lightly sand any surface roughness, particularly around fasteners.

For field-glued floors, use adhesives meeting **ASTM D3498** or **APA Specification AFG-01**, applied in accordance with the manufacturer's recommendations. If OSB panels with sealed surfaces and edges are used, use only solvent-based glues; check with panel manufacturer. Apply continuous line of glue (1/4" thick) on joists, and continuous or spaced line of glue (1/8" thick) in groove of tongue-and-groove panels. Use 6d ring- or screw-shank nails spaced 6" oc at panel ends and 12" oc at intermediate bearings.⁽¹⁰⁾⁽¹³⁾⁽¹⁶⁾

3. Underlayment (over subflooring) – Plywood underlayment shall be (specify appropriate grade)⁽¹⁷⁾:

- APA UNDERLAYMENT EXP 1
- APA UNDERLAYMENT C-C PLUGGED EXT, OR
- APA C-C PLUGGED EXT.

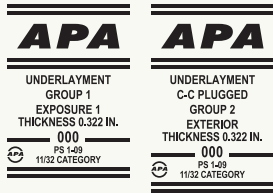

Plywood Performance Category 19/32 or larger, APA RATED STURD-I-FLOOR EXP 1 or APA RATED STURD-I-FLOOR EXT may be specified. Apply underlayment just prior to laying finish floor and protect against damage until finish floor is installed.

For maximum stiffness, install underlayment with the face grain across supports. Stagger underlayment end joints at least one joist spacing (optional under carpet and pad) with respect to subfloor end joints and offset all edge joints by at least two inches from edge joints in the subfloor panels. Underlayment panel end joints should be offset two inches from framing below subfloor to avoid nailing into framing (which may lead to nail pops). **Butt panel ends and edges to a close but not tight fit (1/32" space is recommended).** Nail 6" o.c. along panel edges and 8" o.c. each way throughout remainder of panel with 3d ring-shank nails for panel Performance Categories of 11/32 to

1/2, or 4d spaced 6" o.c. along edges and 12" o.c. each way for panel Performance Categories up to 3/4.⁽¹¹⁾⁽¹³⁾⁽¹⁸⁾ Fastener length should be slightly longer than the total thickness of the underlayment and subfloor.

Fill and thoroughly sand edge joints.⁽¹⁵⁾ Lightly sand any surface roughness, particularly around fasteners.

D. Wall Sheathing

1. Panel wall sheathing shall be (specify appropriate grade):

- APA RATED SHEATHING EXP 1
- APA RATED SHEATHING EXT
- APA STRUCTURAL I RATED SHEATHING EXP 1,
- APA STRUCTURAL I RATED SHEATHING EXT, or
- APA RATED WALL BRACING EXP 1.

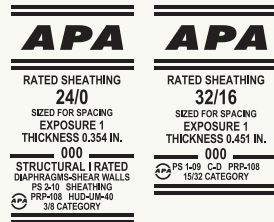

Spacing of 1/8" is recommended at panel ends and edges, unless otherwise indicated by the panel manufacturer.⁽⁹⁾

Unless special nail provisions are required (e.g., high wind areas), nail 6" o.c. along supported panel edges and 12" o.c. at intermediate supports with 6d common nails for panels with a Performance Category of 1/2 and smaller, and 8d for greater thicknesses.⁽¹⁰⁾⁽¹²⁾⁽¹³⁾

Apply weather-resistant barrier over panel wall sheathing.

E. Treated Plywood

1. Fire-retardant-treated plywood – All plywood shall be pressure-treated in accordance with American Wood Protection Association (AWPA) Standard U1 with an approved (high temperature Interior Type A-HT) (Exterior Type) fire retardant. Each panel shall be labeled or marked by an approved independent testing agency. After treatment, plywood shall be dried to an average moisture content of 15 percent or less.

Plywood shall be all-veneer APA RATED SHEATHING (or better, depending on appearance desired) EXP 1 or EXT.

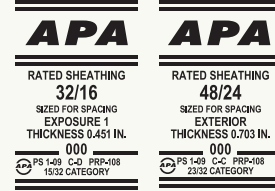

Note: Span Ratings and load capacities are based on untreated panels, and may not apply following fire-retardant treatment (FRT). Obtain structural performance characteristics of FRT panels from the company providing the treatment and redrying service.

2. Preservative-treated plywood –

Treated plywood for (state application) shall be pressure-treated in accordance with AWPAs U1 with (creosote) (pentachlorophenol) (waterborne) preservatives, as required for (coastal water) (wood foundation) (ground contact) (above ground) exposure. Plywood treated with waterborne preservatives shall be dried after treatment to a moisture content of 18 percent or less.

All treated plywood used in the Permanent Wood Foundation System (PWF) shall be marked PS 1, PS 2 or APA Standard PRP-108, and marked by an approved inspection agency certified to inspect preservative-treated wood, indicating compliance with the treating, drying, retention and penetration requirements of AWPAs U1, or equivalent code-approved preservative-treating and quality control requirements. The mark shall also identify the intended use as Permanent Wood Foundation material.

Plywood shall be all-veneer APA RATED SHEATHING (or better, depending on appearance desired) EXP 1 or EXT.

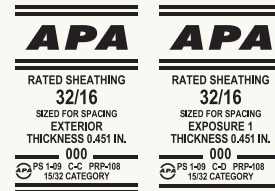

Notes to Panel Specification Guide on page 19.

F. Glued Plywood Components

1. General – All plywood components shall be fabricated in accordance with the appropriate APA Fabrication Specification.⁽¹⁹⁾ Each original plywood panel shall bear the appropriate trademark of APA. Glue shall be of resorcinol or phenolic resin base (for outdoor exposure), or casein with a mold inhibitor (for indoor exposure).

CSI* Division 7 – Thermal and Moisture Protection

A. Siding

Siding shall be (specify appropriate grade):⁽²⁰⁾

- APA RATED SIDING EXT, or
- APA MEDIUM DENSITY OVERLAY (MDO) GENERAL EXT.

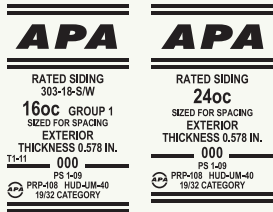

Spacing of 1/8" is recommended at panel ends and edges, unless otherwise indicated by the panel manufacturer. Unless special nail provisions are required (e.g., high wind areas), nail panel siding 6" o.c. along panel edges and 12" o.c. at intermediate supports with 6d nonstaining⁽²¹⁾ box, casing or siding nails for panels with a Performance Category of 1/2 and smaller, and 8d for greater thicknesses.⁽¹⁰⁾⁽¹³⁾

Unless special nail provisions are required (e.g., high wind areas), fasten lap siding installed over panel or lumber sheathing 8" o.c. along bottom edge, or as otherwise recommended by manufacturer. Nail lap siding installed direct to studs or over nonstructural sheathing at each stud. Use 6d nonstaining⁽²¹⁾ box, casing, or siding nails for siding with a Performance Category of 1/2 or smaller, and 8d for thicker panels⁽²²⁾. If siding is applied over nonstructural sheathing, use next larger nail size. Use nonstaining box nails for siding installed over foam insulation sheathing ensuring adequate penetration into the studs to resist wind loads.

Prior to installing siding, apply weather-resistant barrier (e.g., building paper) over studs or sheathing.⁽⁶⁾

All panel edges should be sealed. For panels to be painted, sealer can be paint primer; for panels to be stained, sealer should be a water-repellent preservative compatible with the finish.

B. Soffits

Soffits shall be (specify appropriate grade):⁽⁵⁾

- APA A-C EXT
- APA B-C EXT
- APA C-C P&TS EXT
- APA RATED SIDING 303 EXT,⁽²⁰⁾ or
- APA MEDIUM DENSITY OVERLAY (MDO) GENERAL EXT.⁽²²⁾

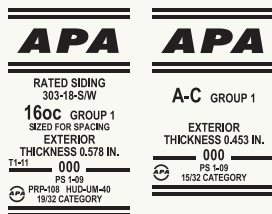

Unless special nail provisions are required (e.g. high wind areas) nail 6" o.c. at supported panel edges and 12" o.c. at intermediate supports, with 6d nonstaining⁽²¹⁾ box, casing, or siding nails for panels with a Performance Category of 1/2 and smaller, and 8d for Performance Categories up to 3/4.⁽¹³⁾

CSI* Division 9 – Finishes (Painting)⁽²⁰⁾

A. Preparation of Surfaces

1. Exterior Panels – Panels to be exposed outdoors shall have all edges sealed. With paint, sealer may be a liberal coat of exterior house paint primer. With stain, seal with water-repellent preservative compatible with finish coat.

Surface shall be clean, dry and free of loose wood fibers.

2. Interior Panels – Surface shall be clean, dry and free of loose wood fibers. Holes and cracks shall be filled with putty or plastic wood (except for rustic type panels intended for stain finish). After dry, sand lightly in the direction of the grain of face veneer or texture to match existing surfaces.

Any tree pitch or sap spots shall be first touched up with a sealer.

B. Application of Finish

(Specify by brush, roller, or spray; brush application of the first coat gives best performance.)

Exterior Panels, Painted – *First coat:* Exterior stain-blocking primer as recommended by manufacturer of finish coat. (May be tinted.) Apply quantity as recommended by paint manufacturer.

Second coat: Top-quality exterior all-acrylic latex house paint designed for use with primer; color as selected. Two topcoats provide better performance.

Exterior Panels, Stained – *First coat:* Top-quality exterior penetrating semi-transparent oil stain where grain showthrough is desired;⁽²³⁾ or heavily pigmented solid-color oil or latex stain where grain is to be masked;⁽²⁴⁾ color as selected. Apply in one or two coats as recommended by manufacturer.

Use stain-blocking primer with light-colored solid-color latex stains.

Interior Panels, Painted – *First coat:* Stain-blocking primer as recommended by manufacturer of finish coat.

Second coat: Flat, semi-gloss or gloss topcoat designed for use with primer; color as selected. Use two topcoats if needed to cover.

Interior Panels, Color Tone – *First coat:* Stain and companion sealer mixed to selected color (or sealer, then stain applied separately).

Second coat: Interior satin varnish (additional coats can be applied as desired for depth of luster).

Interior Panels, Light Stain – *First coat:* Pigmented resin sealer (wiped off when tacky).

Second coat: Clear resin sealer.

Third coat: Tinted undercoat; thin enamel; pigmented sealer; or light stain applied thinly and wiped to the desired color depth; color as selected.

Fourth coat: Interior satin varnish (additional coats can be applied as desired for depth of luster).

*Construction Specifications Institute
Notes to Panel Specification Guide on page 19.

Notes to Panel Specification Guide:

- (1) The APA trademarks shown here are typical examples only. Refer to the following sections for specific panel grade and thickness recommendations.
- (2) Structural I grade (all plies limited to Group 1 species) can be specified when greater stiffness or strength is required.
- (3) Performance Category recommendations are contained in *APA Design/Construction Guide: Concrete Forming, Form V345*.
- (4) Exposure 1 may be specified for applications where temporary exposure to the weather will be required.
- (5) Open soffits or roof sheathing exposed on the underside may be any panel classed Exposure 1 where appearance is not a major consideration.
- (6) Refer to the appropriate application recommendations in this brochure.
- (7) References to APA's recommendations may allow subsequent specification concerning nailing, edge support and panel orientation to be omitted.
- (8) Long dimension of panel may be parallel to supports if panel has adequate thickness. See Table 33 for roof panels applied parallel to supports.
- (9) Supported panel joints shall occur approximately along the centerline of framing with a minimum bearing of 1/2".
- (10) Engineered shear walls and diaphragms may require additional nailing. See recommendations in Tables 29 and 38. Diagonal bracing is not required for braced wall sections when panel wall sheathing, APA RATED WALL BRACING or panel siding (APA RATED SIDING) is used.
- (11) Other code-approved fasteners may be used.
- (12) Fasteners shall be located 3/8" from panel edges.
- (13) See **Table 5, page 14**, for nail dimensions.
- (14) Specify veneer-faced STURD-I-FLOOR with "sanded face" when resilient flooring is to be applied (or see note 17 for additional grades). Otherwise, an additional layer of "sanded face" underlayment is recommended when resilient flooring is to be applied over STURD-I-FLOOR.
- (15) This step may not be necessary under some carpet and structural flooring products – check with flooring manufacturer.
- (16) Some local building codes accept 12" spacing with glue but current IBC and IRC require 6" fastener spacing at edges. When panels with a Performance Category greater than 3/4 are used in glued floors, use same fastener schedule as for nailed-only construction.
- (17) For areas to be covered with resilient flooring or fully adhered carpeting, specify Underlayment or C-C Plugged panel grades marked "sanded face." Underlayment A-C, Underlayment B-C, Marine EXT or sanded plywood grades marked "Plugged Crossbands Under Face," "Plugged Crossbands (or Core)," "Plugged Inner Plies" or "Meets Underlayment Requirements" may also be used under resilient flooring or fully adhered carpeting.
- (18) For panels with a Performance Category of 1/4, nail 3" o.c. along panel edges and 6" o.c. each way throughout remainder of panel, with 3d ring-shank nails. See **Table 14** for underlayment recommendations.
- (19) Design and fabrication specifications for plywood box beams, stressed-skin panels, curved panels, sandwich panels and all-plywood beams are available from APA.
- (20) See *APA Product Guide: Performance Rated Siding, Form E300*.
- (21) Hot-dip or hot-tumbled galvanized steel nails are recommended for most siding applications. For best performance, stainless steel nails or aluminum nails should be considered. APA tests also show that electrically or mechanically galvanized steel nails appear satisfactory when plating meets or exceeds thickness requirements of **ASTM A641 Class 2 coatings**, and is further protected by yellow chromate coating.

Note: Galvanized fasteners may react under wet conditions with the natural extractives of some wood species and may cause staining if left unfinished. Such staining can be minimized if the siding is finished in accordance with APA recommendations, or if the roof overhang protects the siding from direct exposure to moisture and weathering.

- (22) Specify MDO plywood with one face of Medium Density Overlay as described in Voluntary Product Standard PS 1.
- (23) Semitransparent stains may be used on plywood face grades 303-OC, 303-NR and 303-6-W. Other 303 face grades should not be finished with semitransparent stains unless specifically recommended by the panel manufacturer.
- (24) Only latex formulations are recommended on APA 303-SR and 303-NR grades of plywood siding.



GLULAM SELECTION AND SPECIFICATION

Glued laminated timber (glulam) is made up of wood laminations, or “lams,” that are bonded together with adhesives. The grain of all laminations runs parallel with the length of the member. Individual lams typically are 1-3/8 inches thick for southern pine and 1-1/2 inches thick for Western species, although other thicknesses may also be used. Glulam products typically range in net widths from 2-1/2 to 10-3/4 inches, although virtually any width can be custom produced.

Balanced and Unbalanced Beams

Glulam may be manufactured as unbalanced or balanced members.

The most critical zone of a glulam bending member with respect to controlling strength is the outermost tension zone. In unbalanced beams, the quality of lumber used on the tension side of the beam is higher than the lumber used on the corresponding compression side, allowing a more efficient use of the timber resource. Therefore, unbalanced beams have different bending stresses assigned to the compression and tension zones and must be installed accordingly. To assure proper installation of unbalanced beams, the top of the beam is clearly stamped with the word “TOP.” Unbalanced beams are primarily intended for simple-span applications even though they can also be used in multiple-span applications when properly designed.

Balanced members are symmetrical in lumber quality about the mid-height. Balanced beams are used in applications, such as long cantilevers or continuous spans, where either the top or bottom of the member may be highly stressed in tension due to service loads. They can also be used in single-span applications, although an unbalanced beam is more cost-efficient for this use.

STANDARD BEAM LAYUP

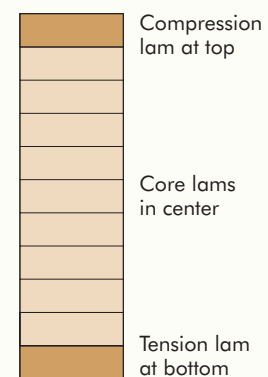

Allowable Design Properties

Allowable design properties are a key factor in specifying glulam. Bending members are typically specified on the basis of the maximum allowable bending stress of the member. For example, a 24F designation indicates a member with an allowable bending stress of 2400 psi. Similarly, a 30F designation refers to a member with an allowable bending stress of 3000 psi. These different stress levels are achieved by varying the species and percentages and grade of higher quality lumber in the beam layup.

To identify whether the lumber used in the beam is visually or mechanically graded, the stress combination also includes a second set of designations. For example, for an unbalanced 24F layup using visually graded lumber, the layup designation may be identified as a 24F-V4. The “V” indicates that the layup uses visually graded lumber. (“E” is used for E-rated or mechanically graded lumber.) The number “4” further indicates a specific combination of lumber used to which a full set of

TABLE 6
DESIGN VALUES FOR STRUCTURAL GLUED LAMINATED TIMBER OF SOFTWOOD SPECIES
(Members stressed primarily in bending)

(Tabulated design values are for normal load duration and dry service conditions.)

Stress Class	Bending About X-X Axis Loaded Perpendicular to Wide Faces of Laminations					Bending About Y-Y Axis Loaded Parallel to Wide Faces of Laminations				Axially Loaded		Fasteners	
	Extreme Fiber in Bending		Compression Perpen- dicular to Grain	Shear Parallel to Grain (Hori- zontal)	Modulus of Elasticity	Extreme Fiber in Bending	Compression Perpen- dicular to Grain	Shear Parallel to Grain (Hori- zontal)	Modulus of Elasticity	Tension Parallel to Grain	Compression Parallel to Grain	Modulus of Elasticity	Specific Gravity for Fastener Design
	Tension Zone Stressed in Tension (Positive Bending)	Compression Zone Stressed in Tension (Negative Bending)											
F_{bx}^+ (psi)	F_{bx}^{-} (psi)	$F_{c,x}$ (psi)	$F_{vx}^{(d)}$ (psi)	E_x (10 ⁶ psi)	F_{by} (psi)	$F_{c,y}$ (psi)	$F_{vy}^{(e)}$ (psi)	E_y (10 ⁶ psi)	F_t (psi)	F_c (psi)	E_{axial} (10 ⁶ psi)	G	
16F-1.3E	1600	925	315	195	1.3	800	315	170	1.1	675	925	1.2	0.42
20F-1.5E	2000	1100	425	210 ^(f)	1.5	800	315	185	1.2	725	925	1.3	0.42
24F-1.7E	2400	1450	500	210 ^(f)	1.7	1050	315	185	1.3	775	1000	1.4	0.42
24F-1.8E	2400	1450 ^(b)	650	265 ^(c)	1.8	1450	560	230	1.6	1100	1600	1.7	0.50
26F-1.9E ^(g)	2600	1950	650	265 ^(c)	1.9	1600	560	230 ^(c)	1.6	1150	1600	1.7	0.50 ⁽ⁱ⁾
28F-2.1E SP ^(g)	2800	2300	740	300	2.1 ⁽ⁱ⁾	1600	650	260	1.7	1250	1750	1.7	0.55
30F-2.1E SP ^{(g)(h)}	3000	2400	740	300	2.1 ⁽ⁱ⁾	1750	650	260	1.7	1250	1750	1.7	0.55 ^t

- (a) For balanced layouts, F_{bx}^- shall be equal to F_{bx}^+ for the stress class. Designer shall specify when balanced layout is required.
 - (b) Negative bending stress, F_{bx}^- , is permitted to be increased to 1850 psi for Douglas-fir and to 1950 psi for southern pine for specific combinations. Designer shall specify when these increased stresses are required.
 - (c) For structural glued laminated timber of southern pine, the basic shear design values, F_{vx} and F_{vy} , are permitted to be increased to 300 psi, and 260 psi, respectively.
 - (d) The design value for shear, F_{vx} , shall be decreased by multiplying by a factor of 0.72 for non-prismatic members, notched members, and for all members subject to impact or cyclic loading. The reduced design value shall be used for design of members at connections that transfer shear by mechanical fasteners. The reduced design value shall be used for determination of design values for radial tension and torsion.
 - (e) Design values are for timbers with laminations made from a single piece of lumber across the width or multiple pieces that have been edge bonded. For timbers manufactured from multiple piece laminations (across width) that are not edge bonded, value shall be multiplied by 0.4 for members with 5, 7, or 9 laminations or by 0.5 for all other members. This reduction shall be cumulative with the adjustment in footnote d.
 - (f) Certain southern pine combinations may contain lumber with wane. If lumber with wane is used, the design value for shear parallel to grain, F_{vx} , shall be multiplied by 0.67 if wane is allowed on both sides. If wane is limited to one side, F_{vx} shall be multiplied by 0.83. This reduction shall be cumulative with the adjustment in footnote d.
 - (g) 26F, 28F, and 30F beams are not produced by all manufacturers, therefore, availability may be limited. Contact supplier or manufacturer for details.
 - (h) 30F combinations are restricted to a maximum 6 in. nominal width.
 - (i) For 28F and 30F members with more than 15 laminations, $E_x = 2.0$ million psi.
 - (j) For structural glued laminated timber of southern pine, specific gravity for fastener design is permitted to be increased to 0.55.
- Design values in this table represent design values for groups of similar glued laminated timber combinations. Higher design values for some properties may be obtained by specifying a particular combination in *APA Data File: Glulam Design Specification, Form Y117*. Design values are for members with 4 or more laminations. Some stress classes are not available in all species. Contact manufacturer for availability.**

design stresses, such as horizontal shear, MOE, etc., are assigned. The glulam industry recently introduced the concept of specifying glulam based on a stress class system similar to that used for MSR lumber or SCL. This requires only specifying an $F_b - E$ value. Typical stress classifications are in Table 6. See also *APA Data Files: Glulam Design Specification* and *Glulam Layout Combinations*, Forms Y117 and Y117SUP, respectively.

Sizes

Glulam is available in both custom and stock sizes. Stock beams are manufactured in commonly used dimensions and cut to length when the beam is ordered from a distributor or dealer. Typical stock beam widths used in residential construction include: 3-1/8, 3-1/2, 5-1/8, 5-1/2, and 6-3/4 inches.

For nonresidential applications, where long spans, unusually heavy loads, or other circumstances control design, custom members are typically specified. Common custom shapes include straight beams, curved beams, pitched and curved beams, radial arches and tudor arches.

Appearance Classification

Glulam is available in a range of appearances, all looking different but having the same structural characteristics for a given strength grade. Glulam appearance classifications are:

Framing. A classification that denotes the member is intended only for use in concealed applications. Beams with this appearance classification are provided in widths designed to fit flush with 2x4 and 2x6 wall framing. **Framing-L** is the same as Framing but denotes that LVL has been used for the outer tension laminations.

Industrial. Used for concealed applications or where appearance is not of primary importance. **Industrial-L** is the same as Industrial but denotes that LVL has been used for outer tension laminations.

Architectural. The appearance of choice in applications where members are exposed to view, because they have a smooth, attractive finish. Stock beams are often supplied with this appearance so they may be exposed to view in the finished structure.

Premium. Available only as a custom order where finished appearance is of primary importance.

All appearance classifications permit natural growth characteristics with varying degrees of open voids permitted. Voids are filled as required by the appearance grade specified using inserts and wood fillers. The appearance classification is not related to lumber layup requirements and thus does not affect design values for the beam. For additional information, refer to *APA Technical Note: Glulam Appearance Classifications for Construction Applications, Form Y110*.

Section Properties and Capacities

When selecting a glulam member, the builder, designer, or specifier must use a member with the required section properties and the applicable design values to satisfy the load carrying requirements. Different load capacities are possible for different stress level combinations of glulam. Tables giving the load carrying capacities for glulam are included in the *APA Data File: Glued Laminated Beam Design Tables, Form S475*.

Camber

Camber is curvature built into a fabricated member (see figure at right) which is opposite in direction and magnitude to the calculated deflection which will occur under gravity loads.

The glulam industry recommends that roof beams be cambered for 1-1/2 times the calculated dead load deflection. This will generally be sufficient to assure that the beam will not visibly sag over a period of many years of loading, as may occur with non-cambered wood products. To achieve a level profile, it is recommended that floor beams be only cambered for 1.0 times the calculated dead load deflection.

Camber for glulam beams is specified as either “inches of camber” or as a radius of curvature that is to be used in the manufacturing process. Commonly used curvature radii for commercial applications are 1,600 and 2,000 feet, although any camber may be specified.

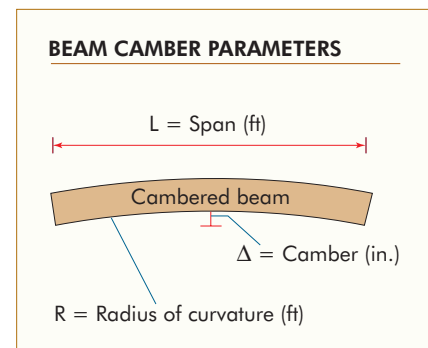

Most residential applications require very little or no camber which, in turn, makes glulam the ideal choice. Stock beams are typically supplied with a relatively flat camber radius of 3,500 feet as shown in Table 7, or zero camber. Thus, they have just the right camber for residential construction. If, however, more camber is required, such as for a long-span roof beam, custom beams are available through manufacturers to meet the most exacting specifications.

For additional information on cambering glulam beams, refer to *APA Technical Note: Glulam Beam Camber, Form S550*, which provides a camber table for various beam spans and radii of curvature.

TABLE 7

CAMBER FOR 3,500-FOOT RADIUS

Span in feet:	10	12	14	16	18	20	22	24	26	28
Camber in inch:	.04	.06	.08	.11	.14	.17	.21	.25	.29	.34

Trademarks and Acceptances

Glulam beams manufactured by APA members are certified with the APA EWS trademark. The mark (as shown) signifies that the manufacturer is committed to a rigorous program of quality verification and testing and that products are manufactured in conformance with *ANSI/AITC Standard A190.1-2007*, American National Standard for Structural Glued Laminated Timber. The APA EWS trademark is recognized by all major model building codes.

Typical information included in an APA EWS trademark is shown at right. This information may vary depending on whether the member is supplied as a custom or stock product.

The diagram shows a horizontal beam with the following text and callouts:

- 1** ——— **B IND** ——— **EWS Y117** ——— **4**
- 7** ——— **EWS 24F-1.8E** ——— **WW** ——— **5**
- 2** ——— **MILL 0000** ——— **ANSI/AITC A190.1-2007** ——— **3**

1 Indicates structural use: B-Simple span bending member. C-Compression member. T-Tension member. CB-Continuous or cantilevered span bending member.

2 Mill number.

3 Identification of ANSI/AITC Standard A190.1, Structural Glued Laminated Timber. ANSI/AITC A190.1 is the American National Standard for glulam beams.

4 Applicable laminating specification.

5 Western woods (see note 6).

6 Structural grade designation. The APA EWS 24F-1.8E designation is a glulam grade commonly used in residential applications. Combining a group of six layup combinations made with Douglas fir-larch, spruce-pine-fir, southern pine, and/or hem-fir, this grade provides strength (allowable bending stress of 2,400 psi and allowable shear stress of 215 psi) and stiffness (modulus of elasticity of 1.8×10^6 psi) needed for typical residential applications, while greatly simplifying the design specification.

7 Designation of appearance grade. FRAMING, FRAMING-L*, INDUSTRIAL, INDUSTRIAL-L*, ARCHITECTURAL, or PREMIUM.
*LVL used for tension laminations.

Glulam Beam Storage and Handling

APA EWS trademarked glulam beams are commonly protected with sealants, primers or wrappings when they leave the mill. But care must be taken during loading, unloading and transporting, as well as in the yard and on the job site.

Sealants on the ends of beams help guard against moisture penetration and checking. Apply a coat of sealant to the ends of beams after trimming. Surface sealants, which can be applied to the top, bottom and sides of beams, resist dirt and moisture and help control checking and grain raising. Use a penetrating sealant if beams will be stained or given a natural finish.

A primer coat also protects beams from moisture and dirt and provides a paintable surface.

Water-resistant wrappings are another way to protect beams from moisture, dirt and scratches. Because sunlight can discolor beams, opaque wrappings are recommended. Beams can be wrapped individually, by the bundle or by the load. In situations where appearance is especially important, the wrapping can be removed after installation to avoid damage.

If possible, store glulam under cover to protect them from rain and sunlight. Place the beams on spaced lumber bunks on level, well-drained ground. In some instances, the wrappings can be used to protect beams until installation. Again, seal ends of beams immediately after trimming. Once beams are installed, allow them to gradually season and adjust to the temperature and moisture conditions of the structure.

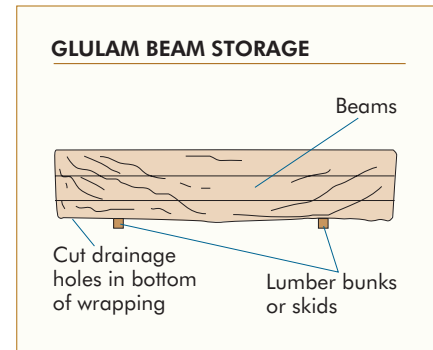

GLULAM SPECIFICATION GUIDE

The following is a guide for preparing specifications for structural glued laminated timber used for bending members such as purlins, beams, or girders or for axially loaded members such as columns or truss chords.

A. General

1. Structural glued laminated timber shall be furnished as shown on the plans and in accordance with the following specifications. (Where other uses or requirements are applicable, modify specifications accordingly.)

2. For custom designed members, shop drawings and details shall be furnished by the (manufacturer) (seller) and approval obtained from the (architect) (engineer) (general contractor) (buyer) before fabrication is begun.

3. The (manufacturer) (seller) (general contractor) shall furnish connection steel and hardware for joining structural glued laminated timber members to each other and to their supports, exclusive of anchorage embedded in masonry or concrete, setting plates, and items field-welded to structural steel. Steel connections shall be finished with a minimum of one coat of rust-inhibiting paint.

B. Manufacture

1. Materials, Manufacture and Quality Assurance – Structural glued laminated timber of softwood species shall be in conformance with **ANSI/AITC Standard A190.1**, American National Standard for Structural Glued Laminated Timber, or other code-approved design, manufacturing and/or quality assurance procedures.

2. End-Use Application – Structural glued laminated timber members shall be manufactured for the following structural uses as applicable: (Simple span bending member – B) (continuous or cantilever span bending member – CB) (compression member – C) (tension member – T).

3. Design Values – Structural glued laminated timber shall provide design values for normal load duration and dry-use condition.⁽¹⁾⁽²⁾ The design should specify a layout combination from **APA Data File: Glulam Design Specifications, Form Y117**, or specify a stress combination from Table 6.

4. Appearance Grade – Glulam shall be (framing) (framing-L) (industrial) (industrial-L) (architectural) (premium) grade⁽³⁾ in accordance with ANSI/AITC Standard A190.1.

5. Laminating Adhesives – Adhesives used in the manufacture of structural glued laminated timber shall meet requirements for (wet-use) (dry-use) service conditions.⁽¹⁾

6. Camber (when applicable) – Structural glued laminated timber (shall) (shall not) be manufactured with a built-in camber.

7. Preservative Treatment (when applicable) – Glulam shall be pressure treated after manufacture in accordance with American Wood Protection Association (AWPA) Standard U1 with (creosote or creosote/coal tar solution) (pentachlorophenol in oil) (pentachlorophenol in light solvent) (copper naphthenate) preservatives as required for (soil contact) (above ground) exposure.⁽⁴⁾

8. Fire Resistance (when applicable) – Glulam shall be sized and manufactured for one-hour fire resistance.⁽⁵⁾ The use of pressure impregnated fire retardant treatments is not recommended.

9. Protective Sealers and Finishes – Unless otherwise specified, sealer shall be applied to the ends of all members. Surfaces of members shall be (not sealed) (sealed with penetrating sealer) (sealed with primer/sealer coating).⁽⁶⁾

10. Trademarks – Members shall be marked with the APA EWS trademark indicating conformance with the manufacturing, quality assurance and marking provisions of ANSI/AITC Standard A190.1.

11. Certificates (when applicable) – A Certificate of Conformance may be provided by the (manufacturer) (seller) to indicate conformance with ANSI/AITC Standard A190.1 if requested.

12. Protection for Shipment – Members shall be (not wrapped) (load wrapped) (bundle wrapped) (individually wrapped) with a water-resistant covering for shipment.

Notes to Specifiers:

- (1) Dry service condition – moisture content of the member will be below 16 percent in service; wet service condition – moisture content of the member will be at or above 16 percent in service. When structural glued laminated timber members are to be preservative treated, wet-use adhesives must be specified.
- (2) An alternative to specifying a layout combination or stress combination is to specify the required allowable design stresses for the specific design application.
- (3) Appearance classifications are described in **APA Technical Note: Glulam Appearance Classifications for Construction Applications, Form Y110**.
- (4) See **APA Technical Note: Preservative Treatment of Glued Laminated Timber, Form S580**.
- (5) When structural glued laminated timber with one-hour fire resistance is specified, minimum size limitations and additional lamination requirements are applicable. Supporting steel connectors and fasteners also must be protected to achieve a one-hour fire rating. Cover with fire-rated (Type X) gypsum wallboard or 1-1/2" wood, to provide the needed protection.
- (6) Specify a penetrating sealer when the finish will be natural or a semitransparent stain. Primer/sealer coatings have a higher solids content and provide greater moisture protection, and are suitable for use with opaque or solid-color finishes.



I-JOIST SELECTION AND SPECIFICATION

I-joists are “I”-shaped engineered wood structural members designed for use in residential and nonresidential construction. The product is prefabricated using sawn or structural composite lumber flanges and OSB webs, bonded together with exterior type adhesives. To simplify the specification and use of I-joists, APA introduced the APA Performance Rated I-Joist (PRI). The joist is limited to a L/480 live load maximum deflection (where L = span) for glued-nailed residential floor applications, a criteria which provides superior floor performance.

TABLE 8

ALLOWABLE SPANS FOR APA EWS PERFORMANCE RATED I-JOISTS – SIMPLE SPAN ONLY

Depth	Joist Designation	Simple Span On Center Spacing			
		12"	16"	19.2"	24"
9-1/2"	PRI-20	16'-7"	15'-2"	14'-4"	13'-5"
	PRI-30	17'-1"	15'-8"	14'-10"	13'-10"
	PRI-40	18'-0"	16'-5"	15'-6"	14'-6"
	PRI-50	17'-10"	16'-4"	15'-5"	14'-5"
	PRI-60	18'-11"	17'-4"	16'-4"	15'-3"
11-7/8"	PRI-20	19'-10"	18'-2"	17'-2"	16'-0"
	PRI-30	20'-6"	18'-9"	17'-8"	16'-6"
	PRI-40	21'-5"	19'-7"	18'-6"	16'-8"
	PRI-50	21'-4"	19'-6"	18'-5"	17'-2"
	PRI-60	22'-7"	20'-8"	19'-6"	18'-2"
	PRI-70	23'-0"	21'-0"	19'-10"	18'-6"
	PRI-90	24'-11"	22'-8"	21'-4"	19'-10"
14"	PRI-40	24'-4"	22'-3"	20'-6"	18'-4"
	PRI-50	24'-4"	22'-2"	21'-0"	19'-7"
	PRI-60	25'-9"	23'-6"	22'-2"	20'-8"
	PRI-70	26'-1"	23'-10"	22'-6"	20'-11"
	PRI-90	28'-3"	25'-9"	24'-3"	22'-7"
16"	PRI-40	26'-11"	24'-3"	22'-1"	19'-9"
	PRI-50	27'-0"	24'-8"	23'-4"	20'-2"
	PRI-60	28'-6"	26'-0"	24'-7"	22'-10"
	PRI-70	29'-0"	26'-5"	24'-11"	23'-1"
	PRI-90	31'-4"	28'-6"	26'-10"	25'-0"
		32'-2"	29'-3"	27'-7"	25'-7"

Notes:

1. Allowable **clear** span applicable to simple-span residential floor construction with a design dead load of 10 psf and live load of 40 psf. The live load deflection is limited to span/480.
2. Spans are based on a composite floor with glued-nailed sheathing meeting the requirements for APA Rated Sheathing or APA Rated STURD-I-FLOOR conforming to PRP-108, PS 1, or PS 2 with a minimum Performance Category of 19/32 (40/20 or 20 oc) for a joist spacing of 19.2 inches or less, or 23/32 (48/24 or 24 oc) for a joist spacing of 24 inches. Adhesive shall meet ASTM D3498 or APA Specification AFG-01. Spans shall be reduced 1 foot when the floor sheathing is nailed only.
3. Minimum bearing length shall be 1-3/4 inches for the end bearings.
4. Bearing stiffeners are **not** required when I-joists are used with the spans and spacings given in this table, except as required for hangers.
5. This span chart is based on uniform loads. For applications with other than uniformly distributed loads, an engineering analysis may be required based on the use of the design properties in [Table 7 of APA Performance Rated I-Joists, Form Z725](#).

APA Performance Rated I-Joists are identified by their net depth followed by a designation, such as PRI-30, which relates to the joist strength and stiffness. APA PRIs are available in four depths: 9-1/2, 11-7/8, 14, and 16 inches.

Most manufacturers supply I-joists to distributors and dealers in lengths up to 60 feet. These are then cut to frequently used lengths such as 16 to 36 feet. Check local supplier for availability.

APA PRI-400

APA PRIs are manufactured in accordance with *PRI-400, Performance Standard for APA EWS I-Joists, Form X720*. This Performance Standard provides an easy-to-use table of allowable spans for applications in residential floor construction, allowing designers and builders to select and use I-joists from various member manufacturers using just one set of span tables. APA PRIs are recognized through *ICC-ES ESR-1405*.

Residential Floor Spans

Some APA PRIs include in their trademarks allowable spans for uniformly loaded residential floor construction at various I-joist spacings. The specific I-joist needed is easily determined by selecting the span and then choosing the I-joist that meets the span, spacing, and loading criteria. See Tables 8 and 9.

For more information on selecting APA I-joists, and for design tables, refer to *APA Performance Rated I-Joists, Form Z725*.

TABLE 9

ALLOWABLE SPANS FOR APA EWS PERFORMANCE RATED I-JOISTS – MULTIPLE SPAN ONLY

Depth	Joist Designation	Multiple Span On Center Spacing			
		12"	16"	19.2"	24"
9-1/2"	PRI-20	18'-1"	16'-6"	15'-7"	13'-5"
	PRI-30	18'-7"	17'-0"	16'-1"	15'-0"
	PRI-40	19'-7"	17'-11"	16'-4"	14'-7"
	PRI-50	19'-5"	17'-9"	16'-9"	15'-7"
	PRI-60	20'-8"	18'-10"	17'-9"	16'-6"
11-7/8"	PRI-20	21'-8"	19'-7"	16'-9"	13'-5"
	PRI-30	22'-4"	20'-5"	18'-10"	15'-0"
	PRI-40	23'-5"	20'-5"	18'-7"	16'-7"
	PRI-50	23'-3"	21'-2"	20'-0"	16'-1"
	PRI-60	24'-8"	22'-6"	21'-2"	19'-7"
	PRI-70	25'-1"	22'-10"	21'-7"	18'-6"
	PRI-80	27'-1"	24'-8"	23'-3"	21'-7"
	PRI-90	27'-11"	25'-5"	23'-11"	22'-2"
14"	PRI-40	25'-11"	22'-5"	20'-5"	18'-3"
	PRI-50	26'-6"	24'-2"	20'-2"	16'-1"
	PRI-60	28'-0"	25'-7"	24'-1"	19'-9"
	PRI-70	28'-5"	25'-11"	23'-2"	18'-6"
	PRI-80	30'-10"	28'-0"	26'-5"	23'-11"
	PRI-90	31'-8"	28'-10"	27'-1"	25'-2"
16"	PRI-40	27'-11"	24'-2"	22'-0"	19'-8"
	PRI-50	29'-6"	24'-3"	20'-2"	16'-1"
	PRI-60	31'-1"	28'-4"	24'-9"	19'-9"
	PRI-70	31'-7"	27'-10"	23'-2"	18'-6"
	PRI-80	34'-2"	31'-1"	29'-3"	23'-11"
	PRI-90	35'-1"	31'-10"	30'-0"	26'-7"

Notes:

1. Allowable **clear** span applicable to multiple-span residential floor construction with a design dead load of 10 psf and live load of 40 psf. The end spans shall be 40 percent or more of the adjacent span. The live load deflection is limited to span/480.
2. Spans are based on a composite floor with glued-nailed sheathing meeting the requirements for APA Rated Sheathing or APA Rated STURD-I-FLOOR conforming to PRP-108, PS 1, or PS 2 with a minimum Performance Category of 19/32 (40/20 or 20 oc) for a joist spacing of 19.2 inches or less, or 23/32 (48/24 or 24 oc) for a joist spacing of 24 inches. Adhesive shall meet ASTM D3498 or APA Specification AFG-01. Spans shall be reduced 1 foot when the floor sheathing is nailed only.
3. Minimum bearing length shall be 1-3/4 inches for the end bearings, and 3-1/2 inches for the intermediate bearings.
4. Bearing stiffeners are **not** required when I-joists are used with the spans and spacings given in this table, except as required for hangers.
5. This span chart is based on uniform loads. For applications with other than uniformly distributed loads, an engineering analysis may be required based on the use of the design properties in *Table 7 of APA Performance Rated I-Joists, Form Z725*.

I-Joist Storage and Handling

Store, stack and handle I-joists with the webs vertical, and try to keep joists level. Do not store I-joists in direct contact with the ground. Maintain at least 12 inches between the ground and the I-joists. Protect I-joists from weather, and use stickers to separate the bundles. If I-joists are delivered wrapped, do not open bundles until time of installation.

When handling I-joists with a crane on the job site (“picking”), take a few simple precautions to prevent damage to the joists and injury to the work crew: pick I-joists in bundles as shipped by the supplier; orient the bundles so that the webs of the I-joists are vertical; and pick the bundles using a spreader bar if necessary. Do not twist or apply loads to the I-joists when they are horizontal. Never use or try to repair a damaged I-joist.

I-joists are not stable until completely installed, and will not carry any load until fully braced and sheathed. Do not allow workers to walk on joists until the joists are fully installed and braced. To avoid accidents, brace and nail each I-joist as it is installed, using hangers, blocking panels, Rim Board, and/or cross-bridging at joist ends and over each support. For additional storage and handling recommendations, refer to *APA Builder Tip: Storage, Handling and Safety Recommendations for APA Performance Rated I-Joists, Form Z735*.

APA PERFORMANCE RATED I-JOIST SPECIFICATION GUIDE

The following is a guide for specifying APA Performance Rated I-Joists (PRI) to be used in residential floor applications. These structural products are available in net depths of 9-1/2 inches, 11-7/8 inches, 14 inches, and 16 inches, and can be used for simple- or multiple-span floor construction. Exterior use, or use of wood I-joists in other than protected dry conditions, is not recommended.

A. General

1. APA PRIs shall be furnished and installed as shown by the approved building plans and installation instructions.

2. The designation of APA PRI shall be based on the applicable loading, joist spacing and spans shown in the plans. PRIs may be selected using Tables 8 and 9. For non-uniform loading conditions requiring an engineering analysis, see [Table 7 of APA Performance Rated I-Joists, Form Z725](#) for PRI joist design properties.

The specification for I-joists required for a specific floor application shall include joist depth, designation, length, and number of pieces required.

Example: 21 pieces – APA 9-1/2" PRI-30 x 30 feet long

3. All accessory products such as I-joist blocking panels, rim boards, squash blocks, web stiffeners, etc., shall be provided and installed in accordance with the applicable installation details shown in [APA Performance Rated I-Joists, Form Z725](#).

4. APA EWS trademarked glued-laminated timber (glulam) or approved structural composite lumber (SCL) shall be furnished for load-bearing joist headers. The depth of these components shall be specified to match the I-joist depth when flush framing is required.

5. The contractor shall use approved connection hardware (joist hangers) as specified in the plans. Such hardware shall be compatible with the width and depth

of APA PRIs furnished, to provide flush nailing surfaces at adjoining members and to prevent rotation.

B. Manufacture

1. Materials, Manufacture, and Quality Assurance. Product quality shall conform to the manufacturer’s approved quality control manual, with compliance assurance services provided by APA in accordance with building code requirements and the applicable code evaluation report.

2. Trademarks. I-joists shall be marked with the APA EWS trademark indicating conformance with the manufacturing, quality assurance, and marking provisions of [APA EWS Standard PRI-400, Performance Standard for APA EWS I-Joists, Form X720](#), or the applicable manufacturer’s code evaluation report.

3. Job Site Shipment. I-joists shall be protected from direct exposure to weather prior to installation.



STRUCTURAL COMPOSITE LUMBER SELECTION AND SPECIFICATION

Structural composite lumber (SCL), which includes laminated veneer lumber (LVL), parallel strand lumber (PSL), laminated strand lumber (LSL) and oriented strand lumber (OSL), is a family of engineered wood products created by layering dried and graded wood veneers, strands or flakes with moisture resistant adhesive into blocks of material known as billets, which are subsequently resawn into specified sizes. A brief description of each product is as follows:

Laminated Veneer Lumber (LVL)

LVL is the most widely used of the structural composite lumber products. It is produced by bonding thin wood veneers together in a large billet. The grain of all veneers is parallel to the long direction. The LVL billet is then sawn to desired dimensions depending on the construction application. Some of the products' many uses are headers and beams, hip and valley rafters, scaffold planking, and the flange material for prefabricated wood I-joists. Because LVL is made with scarfed or lapped jointed veneers, LVL is available in lengths far beyond conventional lumber lengths.

Parallel Strand Lumber (PSL)

PSL is manufactured from veneers clipped into long strands laid in parallel formation and bonded together with an adhesive to form the finished structural section. The length-to-thickness ratio of the strands in PSL is around 300. Like LVL and glulam, this product is used for beam and header applications where high bending strength is needed. PSL is also frequently used as load-bearing columns.

Laminated Strand Lumber (LSL)

Similar to PSL, laminated strand lumber is made from flaked wood strands that have a length-to-thickness ratio of approximately 150. Combined with an adhesive, the strands are oriented and formed into a large mat or billet and pressed. LSL is used in a variety of applications from studs to millwork components.

Oriented Strand Lumber (OSL)

Similar to LSL, oriented strand lumber is also made from flaked wood strands. The strand geometry for OSL results in length-to-thickness ratios of approximately 75. Combined with an adhesive, the strands are oriented and formed into a large mat or billet and pressed. OSL is used in a variety of applications from studs to millwork components.

In SCL billets, the grain of each layer of veneer or flakes runs primarily in the same direction. The resulting products out-perform conventional lumber when either face- or edge-loaded. SCL is a solid, highly predictable and uniform engineered wood product that is sawn to consistent sizes and is virtually free from warping and splitting.

Typical uses for SCL include rafters, headers, beams, joists, studs, and columns. Two or three sections of SCL can be joined together to form 3-1/2-inch or 5-1/4-inch members. These thicker sections readily nest into 2x4 or 2x6 framed walls as headers or columns.

Allowable Strength Properties

Structural properties of SCL are evaluated using methods specified in [ASTM Standard Specification D5456 for Structural Composite Lumber](#). Ongoing quality auditing of SCL is performed by APA. The structural design values for SCL are published on a proprietary basis by manufacturers of SCL and are recognized in their evaluation reports published by ICC ES or APA Product Reports (www.apawood.org/ProductReports). A list of APA EWS SCL manufacturers is available on APA's website (www.apawood.org).

STRUCTURAL COMPOSITE LUMBER (SCL) SPECIFICATION GUIDE

A. General

1. SCL shall be furnished and installed as shown on the approved building plans and in accordance with the specifications of the SCL manufacturer.
2. The contractor shall use approved hardware and connections as specified in the plans.

B. Manufacture

1. **Materials, Manufacture and Quality Assurance.** Product quality shall conform to the manufacturer's approved quality control manual, with certification services provided by APA in accordance with building code requirements and the applicable code evaluation report.

2. **Trademarks.** SCL shall be marked with the APA EWS trademark, indicating conformance with the manufacturer's evaluation report.

3. **Job Site Shipment.** SCL shall be protected from direct exposure to weather prior to installation.



FLOOR CONSTRUCTION

Engineered wood floor systems give builders and designers strength, dependable performance and design flexibility. A variety of floor framing and wood structural panel products can be used in floor construction. To select the appropriate products and floor design, it is essential to define the predicted loads and to consider both the structural requirements and compatibility with the finish floor requirements. Table 10 shows the most common finish floor products and the floor systems that are typically recommended for each.

APA Rated Sturd-I-Floor®

APA RATED STURD-I-FLOOR is a span-rated APA proprietary product designed specifically for use in single-layer floor construction beneath carpet and pad. The product provides all of the proven cost-saving and performance benefits of combined subfloor-underlayment construction. It is manufactured in conformance with **APA PRP-108 Performance Standards** and/or Voluntary

TABLE 10

TYPICAL PANEL FLOOR SPECIFICATIONS BASED ON FINISH FLOOR INSTALLATIONS (All must meet minimum structural requirements^(a) of IBC or IRC)

Finish Floor	Typical Panel Installation ^(b)	Example Specification ^(b)
Carpet and Pad	Single layer of APA Rated Sturd-I-Floor with T&G edges	APA Sturd-I-Floor 24 oc Exposure 1 T&G (for joists spaced 24 inches o.c. or less)
Hardwood Flooring	Single layer of APA Rated Sturd-I-Floor or APA Rated Sheathing	APA Rated Sturd-I-Floor 24 oc Exposure 1 or 48/24 APA Rated Sheathing Exposure 1 (for joists spaced 24 inches o.c. or less) ^(d)
Vinyl (or other thin resilient floor covering) or Glue-down Carpet	APA Rated Sturd-I-Floor or APA Rated Sheathing Exposure 1 plus minimum Performance Category 1/4 APA Underlayment ^(e) Sanded Face Exposure 1	APA Rated Sturd-I-Floor ^(c) 24 oc Exposure 1 or APA Rated Sheathing 48/24 Exposure 1 (for joists spaced 24 inches o.c. or less). Cover with 1/4-inch (or thicker) APA Underlayment ^(f) Sanded Face Exposure 1
Ceramic Tile ^(g)	Two layers minimum Performance Category 19/32 APA Rated Sturd-I-Floor ^(c) Exposure 1	Two layers of minimum Performance Category 19/32 plywood APA Rated Sturd-I-Floor ^(c) 20 oc Exposure 1 (for joists spaced 16 inches o.c. or less)

(a) Floor Span Rating must equal or exceed joist spacing.

(b) Refer to www.apawood.org for installation specifics and alternate installation combinations.

(c) **Plywood** APA Rated Sturd-I-Floor with sanded face. Plywood Rated Sturd-I-Floor is underlayment with a span rating.

(d) Minimum Performance Category 19/32 **plywood** APA Sturd-I-Floor^(c) or APA Rated Sheathing. Minimum Performance Category 23/32 **OSB** APA Sturd-I-Floor or APA Rated Sheathing. See *APA Technical Note: APA Performance Rated Panel Subfloors Under Hardwood Flooring, Form R280*.

(e) APA Underlayment is always plywood.

(f) For rough floors, specify minimum Performance Category 11/32 APA Underlayment^(c).

(g) For other specialty flooring products, including marble and slate, please refer to the finish floor manufacturer's recommendations. Enhanced structural performance may be required for ceramic and natural stone floor products. See *Tile Council of North America (TCNA) Handbook for Ceramic Tile Installation* (www.tileusa.com).

Product Standard PS 1 or PS 2. Plywood APA STURD-I-FLOOR meets PS 1 Underlayment specifications, but in addition to qualifying as underlayment, STURD-I-FLOOR carries a Span Rating (thin underlayment carries no Span Rating). STURD-I-FLOOR is easy to use and specify because the maximum recommended spacing of floor joists – or Span Rating – is stamped on each panel. Panels are manufactured with Span Ratings of 16, 20, 24, 32 and 48 inches. **These assume use of the panel continuous over two or more spans with the long panel dimension or strength axis across supports.***

TABLE 11

APA RATED STURD-I-FLOOR^(a)

Span Rating (Maximum Joist Spacing) (in.)	Panel Performance Category ^(d)	Fastening: Glue-Nailed ^(b)			Fastening: Nailed-Only		
		Nail Size and Type ^(e)	Supported Panel Edges ^(f)	Intermediate Supports	Nail Size and Type ^(e)	Supported Panel Edges ^(f)	Intermediate Supports
16	19/32, 5/8	6d ring- or screw-shank ^(g)	6 ^(h)	12	6d ring- or screw-shank	6	12
20 ⁽ⁱ⁾	19/32, 5/8	6d ring- or screw-shank ^(g)	6 ^(h)	12	6d ring- or screw-shank	6	12
24	23/32, 3/4	6d ring- or screw-shank ^(g)	6 ^(h)	12	6d ring- or screw-shank	6	12
	7/8	8d ring- or screw-shank ^(g)	6	12	8d ring- or screw-shank	6	12
32	7/8	8d ring- or screw-shank ^(g)	6	12	8d ring- or screw-shank	6	12
48	1-3/32, 1-1/8	8d ring- or screw-shank ^(j)	6	(k)	8d ring- or screw-shank ^(j)	6	(j)

- (a) Special conditions may impose heavy traffic and concentrated loads that require construction in excess of the minimums shown. See page 43 for heavy-duty floor recommendations.
- (b) Use only adhesives conforming to APA Specification AFG-01 or ASTM D3498, applied in accordance with the adhesive manufacturer’s recommendations. If OSB panels with sealed surfaces and edges are to be used, use only solvent-based glues; check with panel manufacturer.
- (c) Increased fastening schedules may be required where floor is engineered as a diaphragm.
- (d) Panels in a given Performance Category may be manufactured in more than one Span Rating. Panels with a Span Rating greater than the actual joist spacing may be substituted for panels of the same Performance Category with a Span Rating matching the actual joist spacing. For example, Performance Category 19/32 Sturd-I-Floor 20 oc may be substituted for Performance Category 19/32 Sturd-I-Floor 16 oc over joists at 16 inches on center.

- (e) See Table 5, page 14, for nail dimensions.
- (f) Supported panel joints shall occur approximately along the centerline of framing with a minimum bearing of 1/2 inch. Fasten panels 3/8 inch from panel edges.
- (g) 8d common nails may be substituted if ring- or screw-shank nails are not available.
- (h) Check with local building official; some local jurisdictions permit nail spacing at 12 inches oc.
- (i) Maximum joist spacing for 20 oc Span Rating is 19.2 inches.
- (j) 10d common nails may be substituted with Performance Category 1-1/8 panels if supports are well seasoned.
- (k) Space nails maximum 6 inches for 48-inch spans and 12 inches for 32-inch spans.

Glue-nailing is recommended for STURD-I-FLOOR panels, though panels may be nailed only. Recommendations for both methods are given in Table 11. (See “The APA Glued Floor System,” page 35, for more detailed gluing recommendations.) Always protect smooth panel faces and tongue-and-groove edges from damage prior to and during application. Install with smooth side up. Recommended live loads are given in Table 12.

If long-term exposure to the weather is required, specify Exterior panels.

Although STURD-I-FLOOR is suitable for direct application of carpet and pad, an additional thin layer of underlayment is recommended under tile, sheet flooring or fully adhered carpet. This added layer restores a smooth surface over panels that may have been scuffed or roughened during construction, or that may not have received a sufficiently sanded surface. When plywood STURD-I-FLOOR with “sanded face” is specified, the surface is also suitable for direct application of resilient floor covering. If a “sanded face” panel is to be used, however, care must be taken during construction to prevent damage or roughening of the sanded face. Tongue-and-groove edges are recommended to be glued under thin floor coverings to assure snug joints.

*Note: The Span Rating in the trademark applies when the long panel dimension or strength axis is across supports unless the strength axis is otherwise identified.

TABLE 12

RECOMMENDED UNIFORM FLOOR LIVE LOADS FOR APA RATED STURD-I-FLOOR AND APA RATED SHEATHING WITH STRENGTH AXIS PERPENDICULAR TO SUPPORTS^(a)

Sturd-I-Floor Span Rating	Sheathing Span Rating	Minimum Panel Performance Category	Maximum Span (in.)	Allowable Live Loads (psf) ^(b)							
				Joist Spacing (in.)							
				12	16	19.2	24	32	40	48 ^(c)	
16 oc	24/16, 32/16	7/16 ^(d)	16	185	100						
20 oc ^(e)	40/20	19/32, 5/8	19.2	270	150	100					
24 oc	48/24	23/32, 3/4	24	430	240	160	100				
32 oc	60/32 ^(f)	7/8	32		405	295	185	100			
48 oc	NA	1-3/32, 1-1/8	48			425	290	160	100		55

- (a) Panels 24" or wider applied over two spans or more, dry; normal load duration assumed.
- (b) 10 psf dead load assumed. Live load deflection limit is $l/360$.
- (c) 4x nominal or double 2x framing.
- (d) 19/32 is minimum Performance Category of Rated Sturd-I-Floor.
- (e) While Span Rating is shown as 20 oc, the actual joint spacing is 19.2 inches.
- (f) Check with supplier for availability.

If the floor has become wet during construction, it should be allowed to dry before application of finish floor, including carpet, underlayment, hardwood flooring, ceramic tile, etc. After it is dry, the floor should be checked for flatness, especially at joints.

When floor members are dry, make sure fasteners are flush with or slightly below surface of the STURD-I-FLOOR panels just prior to installation of thin floor coverings. Fasteners should be set if green framing will present nail popping problems upon drying. **Do not** fill nail holes. To minimize the chance of floor squeaks, installers should press panels tightly onto joists by standing on the panel over the joist next to the nailing point. Fill and thoroughly sand edge joints (this step may not be necessary under some carpet and structural flooring products – check recommendations of flooring manufacturer). Fill any other damaged or open areas, such as splits, and sand all surface roughness. (Ensure fill compound is fully cured before sanding because it may continue to expand as it cures.)

FIGURE 1

APA RATED STURD-I-FLOOR 16, 20, AND 24 oc

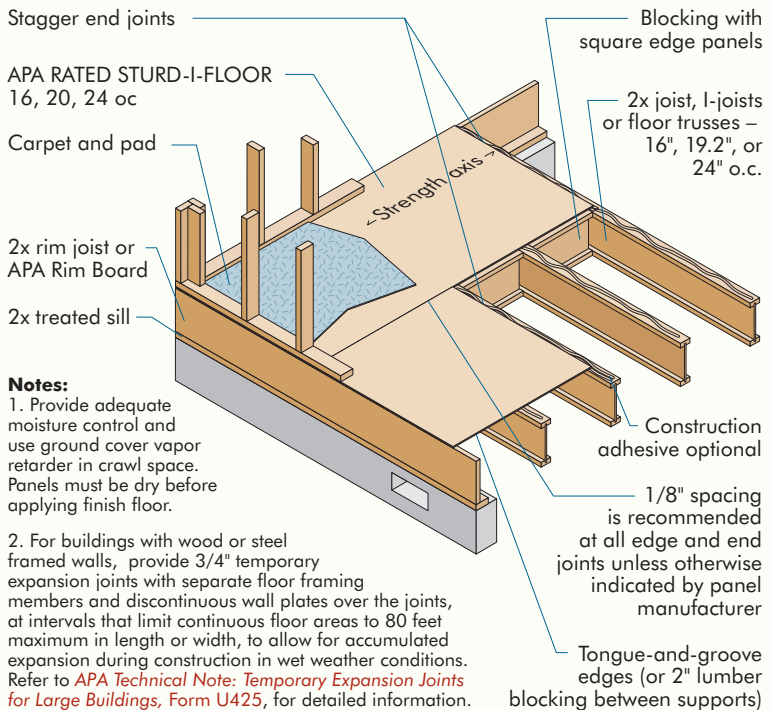

Sturd-I-Floor 32 oc and 48 oc

Install APA RATED STURD-I-FLOOR 48 oc or 32 oc panels over 2x joists or I-joists spaced 32 inches on center (Figure 2). Install APA RATED STURD-I-FLOOR 48 oc over 4x girders (Figure 3). For the 48 oc method, supports may be 2x joists spiked together, 4x lumber, glued laminated timber (glulams), lightweight steel beams, or wood I-joists or floor trusses. Girders of doubled 2x members should have top edges flush to permit smooth panel end joints.

For a low profile with supports 48 inches on center, beams can be set in foundation pockets or on posts supported by footings so that panels bear directly on the sill. If 4x lumber girders are used, they should be air dried and/or set higher than the sill to allow for shrinkage.

In some applications, particularly in hallways and other heavy traffic areas, greater stiffness in the floor may be desirable. Modifications to the 48-inch framing system, such as addition of straight or diagonal blocking, will increase stiffness considerably.



FIGURE 2

APA RATED STURD-I-FLOOR 32 oc AND 48 oc (Over Supports 32" o.c.)

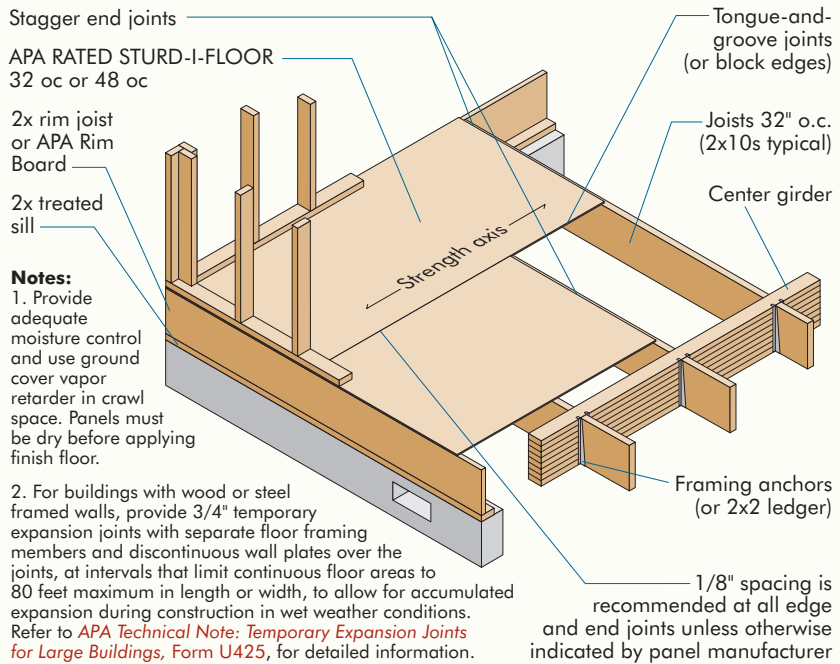
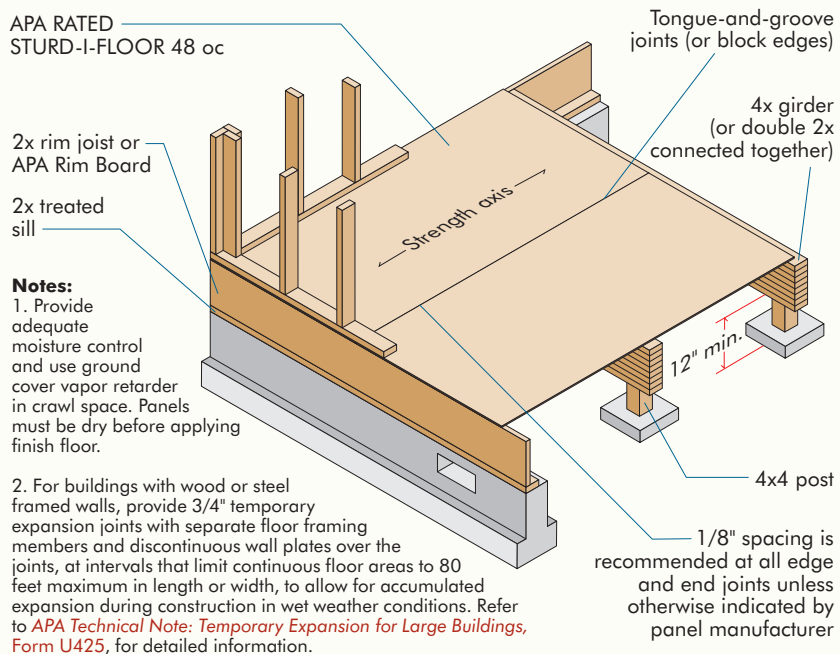

FIGURE 3

APA RATED STURD-I-FLOOR 48 oc (Over Supports 48" o.c.)



APA Performance Rated Rim Board®

A Rim Board is the wood component that fills the space between the sill plate and bottom plate of a wall or, in second floor construction, between the top plate and bottom plate of two wall sections. The Rim Board must match the depth of the framing members between floors or between the floor and foundation to function properly. In addition to supporting the wall loads, the Rim Board ties the floor joists together. It is an integral component in an engineered wood system because it transfers both vertical bearing and lateral forces.



While lumber has been the traditional product used for Rim Boards, it is generally not compatible with the depth of the new generation of wood I-joists used in floor construction. With the increasing use of wood I-joists, a demand for compatible engineered wood Rim Boards has resulted.

APA Performance Rated Rim Boards can be manufactured using plywood, oriented strand board (OSB), glulam, or structural composite lumber (SCL). These engineered wood Rim Boards have less shrinkage than lumber and match the depth of wood I-joists and other engineered wood framing products. They are available in lengths up to 24 feet, depending on the product used.

APA Performance Rated Rim Boards are manufactured in accordance with **Voluntary Product Standards PS 1 or PS 2**, or **ANSI/AITC A190.1** and meet the requirements of **ANSI/APA PRR 410 Standard for Performance-Rated Engineered Wood Rim Boards** or **APA PRR-401 Performance Standard for APA EWS Rim Boards**. ANSI/APA PRR 410 and APA PRR-401 meet or exceed the requirements given in the **ICC ES Acceptance Criteria for Wood-Based Rim Board Products, AC124**.

As glued engineered wood products, APA Rim Boards have greater dimensional stability, higher strength, increased structural reliability, more consistent quality and a lower tendency to check or split than sawn lumber.

The APA Glued Floor System

The APA Glued Floor System is based on thoroughly tested gluing techniques and field-applied construction adhesives that firmly and permanently secure a layer of wood structural panels to wood joists.

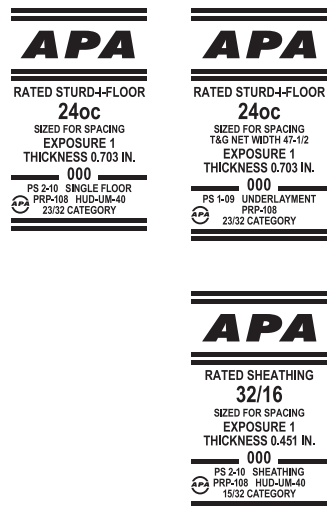
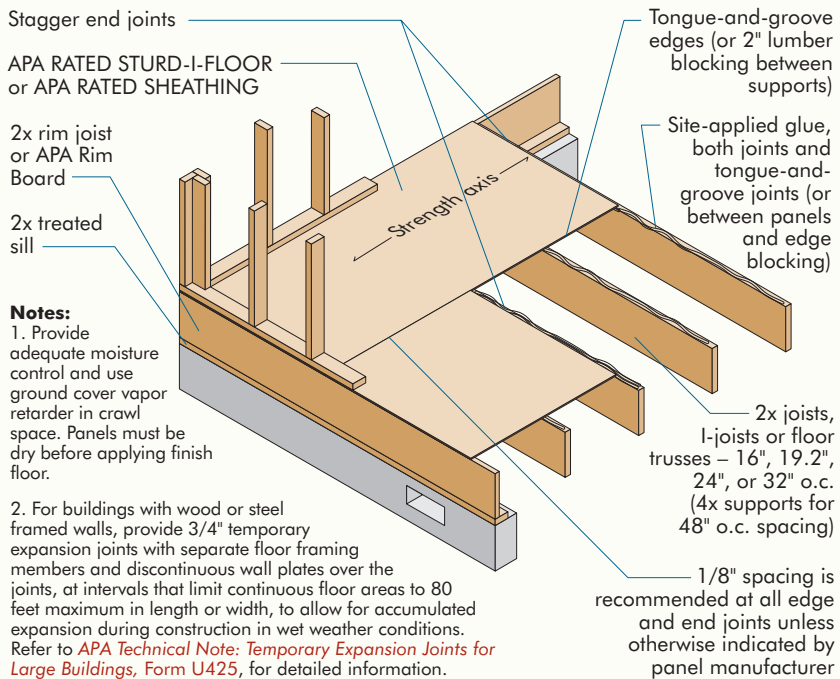

FIGURE 4

APA GLUED FLOOR SYSTEM



Rim Board® is a registered trademark of APA – The Engineered Wood Association.

The glue bond is so strong that floor and joists behave like integral T-beam units. Floor stiffness is increased appreciably over conventional construction, particularly when tongue-and-groove joints are glued. Gluing also helps eliminate squeaks, floor vibration, bounce and nail-popping.

Field-glued floors go down quickly, even in cold weather, using ordinary construction materials and techniques. And like many other panel assemblies that provide excellent sound control, the APA Glued Floor System is ideal for multi-family construction. The large panels with glued tongue-and-groove joints reduce the number of cracks that can “leak” airborne noise.

The system is normally built with Span Rated STURD-I-FLOOR panels (Figure 4), although double-layer floors are also applicable. **In both cases, STURD-I-FLOOR and subflooring panels should be installed continuous over two or more spans with the long dimension or strength axis across supports.**

Panels recommended for glued floor construction are tongue-and-groove APA RATED STURD-I-FLOOR for single-floor construction and APA RATED SHEATHING for the subfloor when used with a separate underlayment layer or with structural finish flooring. An additional layer of underlayment should be applied in areas to be finished with resilient floor coverings, such as tile, linoleum, vinyl or fully adhered carpet. If plywood STURD-I-FLOOR with “sanded face” is specified, the surface is suitable for direct application of resilient floor covering and an additional layer is not required. If a “sanded face panel” is to be used, however, care must be taken during construction to prevent damage or roughening of the sanded face. Exposure 1 or Exterior panels have suitable bond performance for applications subject to moisture during or after construction, as in bathrooms and utility rooms.

Tongue-and-groove panels are highly recommended for single-floor construction. Before each panel is placed, a line of glue is applied to the joists with a caulking gun. The panel tongue-and-groove joint should also be glued, although less heavily to avoid squeeze-out. If square-edge panels are used, edges must be supported between joists with 2x4 blocking. Glue panels to blocking to minimize squeaks. Blocking is not required under structural finish flooring, such as wood strip flooring, or if a separate underlayment layer is installed.

Only adhesives conforming with [ASTM D3498](#) or Performance Specification AFG-01 developed by APA are recommended for use with the Glued Floor System. A number of brands meeting this specification are available from building supply dealers. **If OSB panels with sealed surfaces and edges are to be used, use only solvent-based glues; check with panel manufacturer.** Always follow the specific application recommendations of the glue manufacturer.

Application

For best results, follow these application procedures:

1. Snap a chalk line across joists 4 feet in from wall for panel edge alignment and as a boundary for spreading glue.
2. Spread only enough glue to lay one or two panels at a time or follow specific recommendations of glue manufacturer. Wipe any mud, dirt or water from joists before gluing.
3. Lay first panel with tongue side to wall and nail in place. This protects the tongue of next panel from damage when tapped into place with block and sledgehammer.
4. Apply a continuous line of glue (about 1/4-inch diameter) to framing members. Apply glue in a serpentine pattern on wide areas.
5. Apply two lines of glue on joists where panel ends butt to assure proper gluing of each end.
6. After first row of panels is in place, spread glue in groove of one or two panels at a time before laying next row. Glue line may be continuous or spaced, but avoid squeeze-out by applying a thinner line (1/8 inch) than on joists.
7. Tap second-row panels into place, using a block to protect groove edges.

8. Stagger end joints in each succeeding row, where possible. A 1/8-inch space between all end joints and edges, including tongue-and-groove, is recommended. Use a spacer tool to assure accurate and consistent spacing.

9. **Complete all nailing of each panel before glue sets.** (See Table 11.) Check the glue manufacturer’s recommendations for allowable time. Warm weather accelerates glue setting. Use 6d ring- or screw-shank nails for panels with a Performance Category of 3/4 or smaller, and 8d ring- or screw-shank nails for thicker panels. See Table 5 for nail dimensions. Space nails per Table 11. Closer nail spacing may be required for diaphragm construction. Finished deck can be walked on and will carry construction loads without damage to glue bond.

APA Panel Subflooring

The Span Ratings in Table 13 apply to APA RATED SHEATHING grades only, and are the minimum recommended for the spans indicated. **The spans assume panels continuous over two or more spans with the long dimension or strength axis across supports.***

Recommended live loads are given in Table 12. Spans are limited to the values shown because of the possible effect of concentrated loads.

Panel Span Rating	Panel Performance Category	Maximum Span (in.)	Nail Size & Type ^{(c)(d)}	Maximum Nail Spacing (in.)	
				Supported Panel Edges ^(e)	Intermediate Supports
24/16	7/16	16	6d common	6	12
32/16	15/32, 1/2	16	8d common ^(f)	6	12
40/20	19/32, 5/8	19.2 ^(g)	8d common	6	12
48/24	23/32, 3/4	24	8d common	6	12
60/32 ^(h)	7/8	32	8d common	6	12

(a) For subfloor recommendations under ceramic tile, refer to Table 15. For subfloor recommendations under gypsum concrete, contact manufacturer of floor topping.
 (b) APA RATED STURD-I-FLOOR may be substituted when the Span Rating is equal to or greater than tabulated maximum span.
 (c) Other code-approved fasteners may be used.
 (d) See Table 5, page 14, for nail dimensions.
 (e) Supported panel joints shall occur approximately along the centerline of framing with a minimum bearing of 1/2 inch. Fasteners shall be located 3/8 inch from panel edges.
 (f) 6d common nail permitted if panel has a Performance Category of 1/2 or smaller.
 (g) Span may be 24 inches if a minimum 1-1/2 inches of lightweight concrete is applied over panels.
 (h) Check with supplier for availability.

Nailing recommendations are given in Table 13. Other code-approved fasteners may be used. APA panel subflooring may also be glued for added stiffness and to reduce squeaks using nailing recommendations in Table 11.

Long edges should be tongue-and-groove or supported with blocking unless:

1. A separate underlayment layer is installed with its joints offset from those in the subfloor. The minimum Performance Category of underlayment should be 1/4 for subfloors on spans up to 24 inches and 11/32 or larger panels on spans greater than 24 inches.
2. A minimum of 1-1/2 inches of lightweight concrete is applied over the panels.
3. 3/4-inch wood strip flooring is installed over the subfloor perpendicular to the unsupported edge.

If the floor becomes wet during construction, it should be allowed to dry before application of finish floor, including underlayment, hardwood flooring, ceramic tile, etc. After it is dry, the floor should be checked for flatness, especially at joints.

***Note:** The Span Rating in the trademark applies when the long panel dimension or strength axis is across supports unless the strength axis is otherwise identified.

FIGURE 5

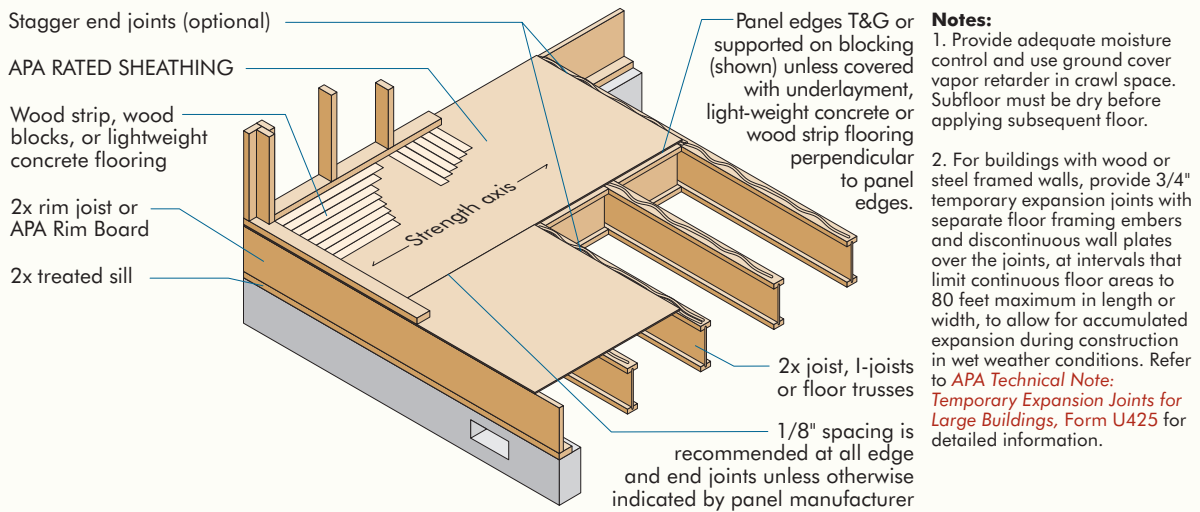
APA PANEL SUBFLOORING

APA RATED SHEATHING Exposure 1 may be used where temporary exposure to moisture or weather is expected during construction. However, only Exterior panels should be used where long-term exposure to moisture or weather will be required.

In some nonresidential buildings, greater traffic and heavier concentrated loads may require construction in excess of the minimums given. Where joists are 16 inches on center, for example, panels with a Span Rating of 40/20 or 48/24 will give additional stiffness and strength. For beams or joists 24 or 32 inches on center, 1-1/8 Performance Category panels (APA RATED STURD-I-FLOOR 48 oc) will provide additional stiffness and strength.

Lightweight Concrete Over APA Panels

APA RATED SHEATHING or STURD-I-FLOOR panels are an excellent base for lightweight concrete floors. See “APA Rated Sturd-I-Floor,” page 31, or “APA Panel Subflooring,” page 37, for application recommendations. For gypsum concrete recommendations, contact manufacturer of floor topping. **Install panels continuous over two or more spans with the strength axis across supports.** Use a moisture barrier when recommended by concrete manufacturer. (See “Noise Transmission Control,” page 77, and Figure 38 for an illustration of a typical assembly.)

APA Plywood Underlayment

Underlayment is a special grade of plywood that has enhanced resistance to face-veneer punctures. This is accomplished by imposing special limitations on the face veneer thickness, species of the face veneer and voids beneath the face veneer. Other grades, such as A-C Exterior, are only suitable if they have the additional Underlayment designation or “Plugged Crossbands Under Face” noted in the trademark. Plywood meeting the Underlayment standard in PS 1, will have the word, “Underlayment” in the trademark (see example on page 10). Plywood STURD-I-FLOOR, however, also meets the enhanced puncture-resistance requirements for Underlayment, in addition to being Span Rated. (See “APA Rated Sturd-I-Floor,” page 31.) Refer to *APA Data File: Installation and Preparation of Plywood Underlayment for Resilient Floor Covering, Form L335*, for installation recommendations.

Underlayment grades of plywood have a solid, touch-sanded surface for direct application of carpet and pad. For areas to be covered with resilient floor covering, specify panels with “sanded face,” or certain other grades as noted in Table 14. Special inner-ply construction of Underlayment resists dents and punctures from concentrated loads. Applied as recommended, plywood Underlayment is also dimensionally stable and eliminates excessive swelling and subsequent buckling or humps around nails.

TABLE 14

APA PLYWOOD UNDERLAYMENT^(a)

Plywood Grades ^(b)	Application	Minimum Plywood Performance Category	Fastener Size and Type ^(c)	Maximum Fastener Spacing (in.) ^(d)	
				Panel Edges ^(e)	Intermediate
APA UNDERLAYMENT APA C-C Plugged EXT APA RATED STURD-I-FLOOR (19/32 or larger Performance Category)	Over smooth subfloor	1/4	3d x 1-1/4-in. ring- or screw-shank nails	3	6 each way
	Over lumber subfloor or uneven surfaces	11/32	min. 12-1/2 gage (0.099 in.) shank dia. ^(f)	6	8 each way

(a) For underlayment recommendations under ceramic tile, refer to Table 15.

(b) In areas to be finished with resilient floor coverings such as tile or sheet vinyl, or with fully adhered carpet, specify Underlayment, C-C Plugged or veneer-faced STURD-I-FLOOR with “sanded face.” Underlayment A-C, Underlayment B-C, Marine EXT or sanded plywood grades marked “Plugged Crossbands Under Face,” “Plugged Crossbands (or Core),” “Plugged Inner Plies” or “Meets Underlayment Requirements” may also be used under resilient floor coverings.

(c) See Table 5, page 14, for nail dimensions.

(d) Fasteners for 5-ply plywood underlayment panels and for panels with a Performance Category greater than 1/2 may be spaced 6 inches on center at edges and 12 inches each way intermediate.

(e) Fasten panels 3/8" from panel edges.

(f) Use 4d x 1-1/2" ring- or screw-shank nails, minimum 12-1/2 gage (0.099") shank diameter, for underlayment panels with a Performance Category of 19/32 to 3/4.

FIGURE 6

INSTALLATION OF APA PLYWOOD UNDERLAYMENT

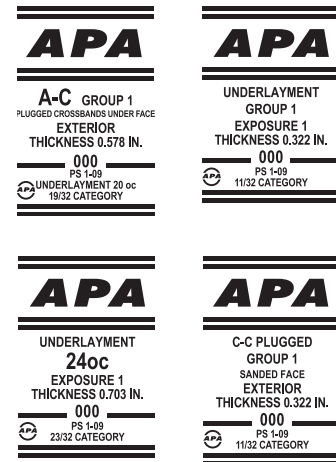
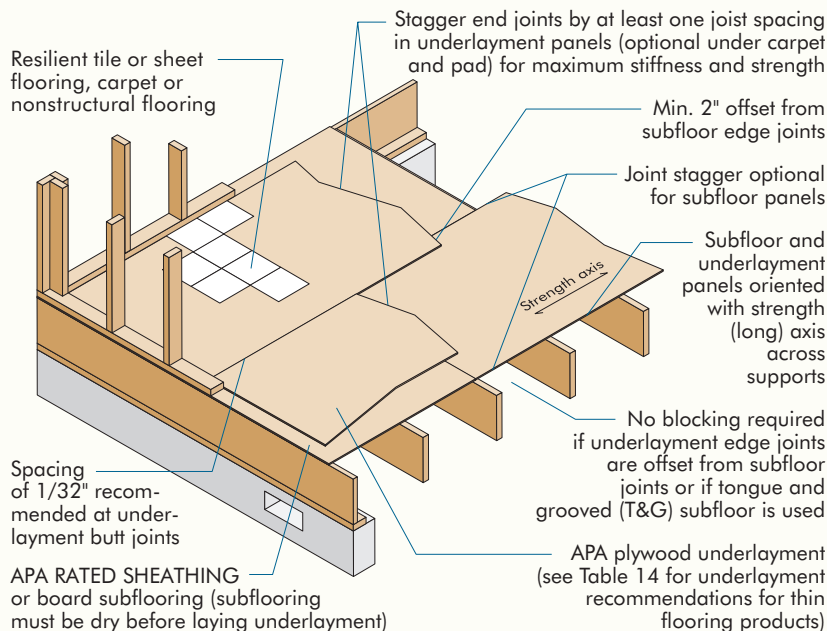

Always protect plywood Underlayment against physical damage or water prior to application. Panels should, however, be allowed to equalize to atmospheric conditions by standing individual panels on edge for several days before installation.

Install plywood Underlayment, smooth side up, immediately before laying the finish floor. For maximum stiffness, place face grain across supports. Edge joints of underlayment panels should be offset by at least 2 inches from joints of subfloor panels. Underlayment end joints should be offset from subfloor end joints by at least one joist spacing, and Underlayment end joints should be offset from floor joists by 2 inches, so that nails miss the framing (to minimize the chance of nail pops).

Begin fastening at one edge next to a preceding panel. Assuring that the panel is uniformly flat, continue by fully fastening toward opposite edge. If power-driven fasteners are used, foot pressure should be applied near the fastener to ensure firm contact between the Underlayment and subfloor. Make sure fasteners are flush with, or just slightly below, surface of Underlayment just prior to installation of resilient floor coverings such as tile, or sheet vinyl. (See [Table 14](#) for Underlayment recommendations for thin flooring products.) Fill and thoroughly sand edge joints. (This step may not be necessary under some carpet and structural flooring products – check recommendations of flooring manufacturer.) Fill any other damaged or open areas, such as splits, and sand all surface roughness. (Ensure fill compound is fully cured before sanding because it may continue to expand as it cures.)

The plywood Underlayment needed to bridge an uneven floor will depend on roughness and loads applied. Although a minimum 11/32 Performance Category is recommended, 1/4 Performance Category plywood Underlayment may also be acceptable over smooth subfloors, especially in remodeling work. (See [Table 14](#).)

Where floors may be subject to temporary moisture, use panels with exterior glue (Exposure 1) or APA C-C PLUGGED Exterior. APA C-D PLUGGED is not an adequate substitute for Underlayment grade since it does not have equivalent face veneer puncture resistance.

Hardwood Flooring Over APA Panel Subfloors

APA panel subfloor spans for 3/4-inch hardwood strip flooring are limited to maximum spacing of floor framing listed in [Table 12](#). For improved stiffness, and to help eliminate floor squeaks when hardwood flooring is installed, spans reduced from the maximum are recommended by the National Wood Floor Association (NWFA)*. NWFA also recommends the use of minimum 23/32 Performance Category OSB or 19/32 Performance Category plywood as a subfloor material.

Because hardwood flooring is sensitive to moisture, make sure subflooring panels are dry before hardwood is installed. Use a moisture meter to measure the moisture content of the subfloor. Do not install hardwood unless subfloor moisture level is within a range consistent with the hardwood manufacturer's recommendations. If the home is built over a crawl space, make sure the crawl space is dry and well-drained. A 6-mil polyethylene vapor retarder should be installed on the ground in the crawl space.

Follow the recommendations of the National Wood Flooring Association (NWFA) for the hardwood flooring product being used and its storage and handling, and for acclimatizing the hardwood prior to installation on the subflooring. Also see [APA Technical Note: Performance Rated Panel Subfloors under Hardwood Flooring, Form R280](#).

Ceramic Tile Over APA Plywood Floors

Recommendations for several plywood floor systems suitable for application of ceramic tile are given in [Table 15](#), based on specifications of the Tile Council of North America (TCNA).** In designing such a floor system, expected live loads, concentrated loads, impact loads and dead loads, including weight of the tile and setting bed, need to be considered. For additional details and assemblies, see [Technical Topic: Ceramic Tile Over Wood Structural Panel Floors, Form TT-006](#), at www.apawood.org.

*National Wood Flooring Association, 111 Chesterfield Industrial Boulevard, Chesterfield, Missouri 63005; Phone (800) 422-4556 (USA), (800) 848-8821 (Canada).

**Tile Council of North America, Inc., 100 Clemson Research Blvd., Anderson, South Carolina 29625; Phone (864) 646-8453.

TABLE 15

**APA FLOOR SYSTEMS FOR CERAMIC TILE FLOORING
 BASED ON THE TILE COUNCIL OF NORTH AMERICA HANDBOOK FOR CERAMIC TILE INSTALLATION**

TCNA No.	Service Classification ^{(a)(b)}	Max. Joist Spacing (in. o.c.)	Tile Adhesive	Underlayment Layer	Subfloor Layer	Comment
F141	Light Commercial	16	Portland cement paste, dry-set mortar or latex-portland cement mortar	Mortar bed (1-1/4" minimum)	19/32" Exposure 1 T&G plywood	Cleavage membrane
F142	Residential	16	Organic	19/32" Exposure 1 plywood	19/32" Exposure 1 T&G plywood	—
F143	Residential or Light Commercial or (with special tile), Heavy	16	Epoxy	19/32" Exposure 1 plywood	19/32" Exposure 1 T&G plywood	15/32" plywood underlayment layer gives "Residential" performance
F144	Residential or Light Commercial	16	Dry-set mortar or latex-portland cement mortar	Cementitious backer units or fiber cement underlayment	23/32" Exposure 1 T&G plywood	19/32" plywood subfloor gives "Residential" performance
F145	Residential or Light Commercial	16	Portland cement paste, dry-set mortar or latex-portland cement mortar	3/4" Minimum mortar bed	23/32" Exposure 1 plywood	Cleavage membrane + metal lath
F146	Light Commercial	16	Dry-set mortar or latex-portland cement mortar	Coated glass-mat backer board	19/32" Exposure 1 plywood	2" x 2" or larger tile only
F147	Residential	24 ^(c)	Latex-portland cement mortar or dry-set mortar	3/8" Exposure 1 plywood plus uncoupling membrane	23/32" Exposure 1 T&G plywood	4" x 4" or larger tile only
F148	Residential	19.2	Latex-portland cement mortar or dry-set mortar	Uncoupling membrane	23/32" Exposure 1 T&G plywood	—
F149	Residential	24	Latex-portland cement mortar	19/32" Exposure 1 plywood	23/32" Exposure 1 T&G plywood	—
F150	Residential or Light Commercial	16	Latex-portland cement mortar	19/32" Exposure 1 plywood	19/32" Exposure 1 plywood	15/32" plywood underlayment layer gives "Residential" performance
F151	Residential	24	Dry-set mortar or latex-portland cement mortar	Coated glass mat backer board	7/8" Exposure 1 T&G plywood	8" x 8" or larger tile only
F152	Residential	24 ^(c)	Latex-portland cement mortar	3/8" Exposure 1 plywood	23/32" Exposure 1 T&G plywood	4" x 4" or larger tile only

Continued on next page

TABLE 15 continued

TCNA No.	Service Classification ^{(a)(b)}	Max. Joist Spacing (in. o.c.)	Tile Adhesive	Underlayment Layer	Subfloor Layer	Comment
F155	Residential ^(d)	24	Latex-portland cement mortar	19/32" Exposure 1 plywood	23/32" Exposure 1 T&G OSB or plywood	OSB subfloor OK
F160	Light Commercial	24	Latex-portland cement mortar	3/8" plywood	23/32" Exposure 1 T&G plywood	8" x 8" or larger tile only
F170	Residential or Light Commercial	16	Latex-portland cement mortar	Fiber-reinforced gypsum panel	19/32" Exposure 1 plywood	—
F175	Residential or Light Commercial	16	Dry-set mortar or latex-portland cement mortar	Cementitious-coated foam backerboard	19/32" Exposure 1 plywood	8" x 8" or larger tile only
F180	Residential or Light Commercial	16		Poured gypsum minimum 3/4"	23/32" Exposure 1 T&G plywood	Uncoupling Membrane
F185	Residential	19.2	Latex-portland cement mortar	Cementitious self-leveling	23/32" Exposure 1 T&G plywood	—
RH122	Residential	16	—	Mortar bed	23/32" Exposure 1 T&G plywood	Crack isolation, waterproof, or uncoupling membrane
RH123	Residential	16	—	Mortar bed	23/32" Exposure 1 T&G plywood	Crack isolation waterproof, or uncoupling membrane
RH130	Residential or Light Commercial	16	Latex-portland cement mortar	Light Commercial-19/32" Exposure 1 plywood	19/32" Exposure 1 T&G plywood	Use of 15/32" plywood underlayment layer gives "Residential" performance
RH135	Residential or Light Commercial	16	Dry-set mortar or latex-portland cement mortar	Cementitious backer unit	23/32" Exposure 1 T&G plywood	Use of 19/32" plywood subfloor gives "Residential" performance
RH140	Residential	19.2	Latex-portland cement mortar	Cementitious self-leveling	23/32" Exposure 1 T&G plywood	—
RH141	Light Commercial	16	Latex-portland cement mortar	Cementitious self-leveling	19/32" Exposure 1 T&G plywood	Use of glass tile may lower service classification

(a) Order of increasing serviceability: Residential, Light Commercial, Moderate and Heavy

(b) As typically performed, the **ASTM C 627 Robinson-Type Floor Tester** delivers three, simultaneous dynamic, 300-pound concentrated wheel loads moving in a 30-inch-diameter circle over the surface of test assembly. The number of cycles the system withstands without failure determines its Service

Classification. One criterion used to determine failure is a maximum deflection of L/360 under the three **concentrated** loads.

(c) 1-1/2 inch net support width permitted with 8x8 inches or larger tile—otherwise 2-1/4 inches net support width is required.

(d) Passed ASTM C 627 tests with a "Light Commercial" rating using plywood as the subfloor and then again with OSB as the subfloor.

APA Panel Stair Treads and Risers

A growing number of builders and manufacturers are using APA panels for treads and risers of both site-fabricated and prefabricated stairs in closed-riser stairways. Risers support the front and back of the tread, creating a very short effective span.

APA panel stair treads may be used interchangeably with boards when the system is to include closed risers. Maximum span between stringers is 42 inches (check local code requirements). Rounded nosing may be machined into the tread, but should be covered by a finish flooring material such as carpet and pad in order to prevent excessive wear or damage to veneers exposed by rounding. Risers may be any available APA panel grade with a Performance Category of at least 19/32. Panel grade and Performance Category recommendations for the treads are given in Table 16. Glue is recommended to improve stiffness of connections and to eliminate squeaks. Apply construction adhesive meeting ASTM D3498 or APA Performance Specification AFG-01 to all joints, with particular attention to the connection at the back riser. Regardless of where glue is used, nail all edges of treads as indicated in Figure 7. Detail A is the simplest system, but Detail B is preferred since it eliminates end-grain nailing at the back riser and may be used for all recommended panels.

Heavy Duty Plywood Floors

Above-grade plywood floors may be designed to support forklift trucks in areas of heavy loading or to support relatively high loads imposed by warehouse shelving or stacked storage. Heavy-duty plywood floors also make excellent mezzanine decks and vibration-resistant surfaces for mounting computer equipment.

Tables 17 and 18 give plywood recommendations for uniform and concentrated (e.g., forklift traffic) loads. **These assume the use of plywood continuous over two or more spans with face grain across supports.** Structural edge support must be provided where high concentrated loads occur. Where no lift-truck use is expected, 2-inch wood framing is adequate.

In addition to providing structural strength, a wearing surface should be provided to resist crushing wood cells and avoid abrasion whenever an industrial floor is subject to hard wheel or caster traffic. An expendable layer of plywood or a dense wear surface, such as tempered hardboard, should be used if wheels are small, hard or heavily loaded.

TABLE 16

APA PANEL STAIR TREADS

Panel Grade ^(a)	Minimum Performance Category	
	Nail-Glued	Nailed-Only
APA RATED		
STURD-I-FLOOR	19/32	23/32

(a) Other appropriate APA panel grades may be substituted for Sturd-I-Floor, providing minimum thickness complies with recommendations above.

FIGURE 7

APA PANEL STAIR TREADS AND RISERS

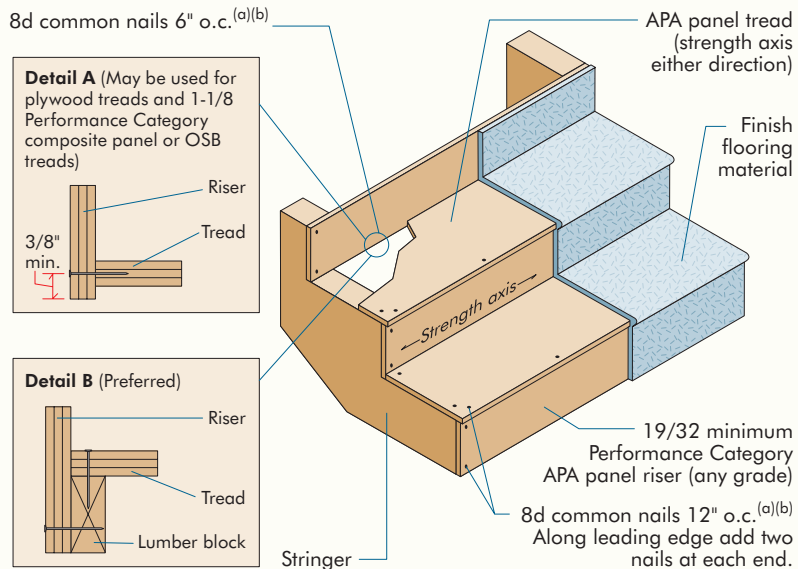

(a) Predrill tread end grain at mid-thickness with 3/32" bit. Maintain at least 3/8" edge distance in riser.
 (b) See Table 5, page 14, for nail dimensions.

TABLE 17

PS 1 PLYWOOD SPAN RATING OR PERFORMANCE CATEGORY RECOMMENDATIONS FOR UNIFORMLY LOADED HEAVY DUTY FLOORS^(a) (Deflection limited to 1/240 of span.)

Uniform Live Load (psf)	Center-to-Center Support Spacing (inches) (Nominal 2-Inch-Wide Supports Unless Noted)					
	12 ^(b)	16 ^(b)	19.2 ^(b)	24 ^(b)	32	48 ^(c)
50	32/16, 16 oc	32/16, 16 oc	40/20, 20 oc	48/24, 24 oc	48 oc	48 oc
100	32/16, 16 oc	32/16, 16 oc	40/20, 20 oc	48/24, 24 oc	48 oc	1-1/2 ^(d)
125	32/16, 16 oc	32/16, 16 oc	40/20, 20 oc	48/24, 24 oc	48 oc	1-3/4 ^(d) , 2 ^(d)
150	32/16, 16 oc	32/16, 16 oc	40/20, 20 oc	48/24, 48 oc	48 oc	1-3/4 ^(e) , 2 ^(d)
200	32/16, 16 oc	40/20, 20 oc	48/24, 24 oc	48 oc	1-1/8 ^(e) , 1-3/8 ^(d)	2 ^(e) , 2-1/2 ^(d)
250	32/16, 16 oc	40/20, 24 oc	48/24, 48 oc	48 oc	1-3/8 ^(e) , 1-1/2 ^(d)	2-1/4 ^(e)
300	32/16, 16 oc	48/24, 24 oc	48 oc	48 oc	1-1/2 ^(e) , 1-5/8 ^(d)	2-1/4 ^(e)
350	40/20, 20 oc	48/24, 48 oc	48 oc	1-1/8 ^(e) , 1-3/8 ^(d)	1-1/2 ^(e) , 2 ^(d)	
400	40/20, 20 oc	48 oc	48 oc	1-1/4 ^(e) , 1-3/8 ^(d)	1-5/8 ^(e) , 2 ^(d)	
450	40/20, 24 oc	48 oc	48 oc	1-3/8 ^(e) , 1-1/2 ^(d)	2 ^(e) , 2-1/4 ^(d)	
500	48/24, 24 oc	48 oc	48 oc	1-1/2 ^(d)	2 ^(e) , 2-1/4 ^(d)	

- (a) Use plywood with T&G edges, or provide structural blocking at panel edges, or install a separate underlayment.
- (b) A-C Group 1 sanded plywood panels may be substituted for span-rated Sturd-I-Floor panels (1/2 Performance Category for 16 oc; 5/8 Performance Category for 20 oc; 3/4 Performance Category for 24 oc).

- (c) Nominal 4-inch-wide supports.
- (d) Group 1 face and back, any species inner plies, sanded or unsanded, single layer. Numbers given are Performance Categories.
- (e) All-Group 1 or Structural I plywood, sanded or unsanded, single layer. Numbers given are Performance Categories.

TABLE 18

PS 1 PLYWOOD SPAN RATING OR PERFORMANCE CATEGORY RECOMMENDATIONS FOR FLOORS CARRYING FORK-TRUCK TRAFFIC^{(a)(b)(c)} (Plywood grade is all-Group 1 or Structural I A-C or C-C Plugged, except where 1-1/8 STURD-I-FLOOR 48 oc is noted.)

Tire Tread Print Width (in.)	Load per Wheel (lbs.)	Center-to-Center Support Spacing (in.) (Minimum 3-Inch-Wide Supports)			
		12	16	19.2	24
3	500	48 oc	48 oc	48 oc	48 oc
	1000	1-1/4	1-1/4	1-1/4	1-1/4
	1500	1-1/2	1-3/4	1-3/4	1-3/4
	2000	2	2	2-1/4	2-1/4
5	1000	48 oc	48 oc	1-1/8	1-1/8
	1500	1-1/8	1-1/8	1-1/4	1-1/4
	2000	1-1/4	1-1/2	1-1/2	1-3/4
	2500	1-1/2	2	2	2
	3000	1-3/4	2	2-1/4	2-1/4
7	2000	1-1/8	1-1/8	1-1/4	1-1/4
	3000	1-1/4	1-1/2	1-1/2	1-3/4
	4000	1-3/4	1-3/4	1-3/4	2
	5000	2	2	2-1/4	2-1/2
	6000	2-1/4	2-1/2	2-3/4	3
	7000	2-1/4	2-1/2	2-3/4	3
9	3000	1-1/4	1-1/4	1-1/4	1-1/4
	4000	1-1/2	1-1/2	1-3/4	1-3/4
	5000	1-3/4	1-3/4	2	2
	6000	2	2	2-1/4	2-1/4
	7000	2-1/4	2-1/4	2-3/4	2-3/4

- (a) Structural blocking (3x4 or 2x6 min.) required at all panel edges. Support blocking with framing anchors of adequate capacity or similar devices.
- (b) Provide a wearing surface such as Plyron, polyethylene or a separate layer of plywood, hardboard or other hard surface when loads are due to casters, or small, hard wheels. A wearing surface

- should also be considered for areas where fork-truck traffic is stopping, starting or turning in a tight radius.
- (c) Use ring- or screw-shank nails with length sufficient to penetrate framing 1-1/2" or panel thickness, whichever is greater. Space nails maximum 4" o.c. at panel edges and 8" o.c. at intermediate supports.



WALL CONSTRUCTION

Building codes require that walls resist wind pressures caused by the design wind speeds, resist wall-racking forces and provide weather protection. This section provides details on how wood structural panels can be used to meet these fundamental requirements.

APA Sturd-I-Wall®

The APA Sturd-I-Wall system consists of APA RATED SIDING (panel or lap) applied direct to studs or over nonstructural fiberboard, gypsum or rigid foam insulation sheathing*. Nonstructural sheathing is defined as sheathing not recognized by building codes for meeting both bending and racking strength requirements.

*Where panel siding is applied over foam sheathing, see APA publication *APA Rated Siding Panels over Rigid Foam Insulation Sheathing, Form C465*.

TABLE 19

FASTENING APA RATED SIDING (PANEL) APPLIED DIRECT-TO-STUDS OR OVER NONSTRUCTURAL SHEATHING^{(a)(b)(c)(d)(e)}

APA Rated Panel Siding	Minimum Nail ^(f)		Wall Stud Spacing (in. o.c.)	Panel Nail Spacing		Maximum Wind Speed (mph)		
	Shank Diameter (in.)	Penetration in Framing (in.)		Edges ^(g) (in. o.c.)	Intermediate Supports (in. o.c.)	Wind Exposure Category		
						B	C	D
3/8 Performance Category APA MDO GENERAL	0.113	1.5	16	6	12	110	90	90
			24	6	6	140	120	110
				6	6	90	NP	NP
APA Rated Siding 16 oc	0.113	2.0	16	6	12	125	105	90
APA Rated Siding 24 oc			6	6	140	120	110	
			6	6	100	85	NP	
					6	140	120	110

(a) Table is based on wind pressures acting toward and away from building surfaces, at 30-ft height in wall Zone 5 (corners) with smallest effective area, per Section 6.4.2.2 of ASCE 7-05 and Section R301.2 of the 2009 IRC. Stud specific gravity = 0.42.

(b) Recommendations of siding manufacturer may vary.

(c) For use as wood structural panel wall bracing, the minimum fastener spacing of 6" o.c. at panel edges and 12" o.c. at intermediate supports shall be sufficient except:

(1) For braced wall section with Performance Category 3/8 panel siding applied horizontally over studs 24" o.c., space nails 3" o.c. along panel edges.

(d) Hot-dip galvanized nails are recommended for most siding applications, see *Siding Fasteners* section on page 48 for more information.

(e) Maximum stud spacing shall be in accordance with Table 21A.

(f) See Table 5, page 14, for nail dimensions.

(g) Supported panel joints shall occur approximately along the centerline of framing with a minimum bearing of 1/2". Fasteners shall be located 3/8" from panel edges. Siding installed over two or more spans.

TABLE 20

APA RATED LAP SIDING APPLIED DIRECT-TO-STUDS OR OVER NONSTRUCTURAL SHEATHING^{(a)(b)(c)(d)(e)}

Minimum Nail ^(f)		Minimum Performance Category (in.)	Wall Stud Spacing (in. o.c.)	Lap Siding Width (in.)	Maximum Wind Speed (mph)		
Shank Diameter (in.)	Penetration in Framing (in.)				Wind Exposure Category		
					B	C	D
0.113	1.5	3/8	16	6	140	120	110
				8	140	120	110
				12	120	100	90
		7/16	16	6	140	120	110
				8	140	120	110
				12	120	100	90
	7/16	24	6	140	120	110	
			8	120	100	90	
			12	90	NP	NP	

- (a) Table is based on wind pressures acting toward and away from building surfaces, at 30-ft height in wall Zone 5 (corners) with smallest effective area, per Section 6.4.2.2 of ASCE 7-05 and Section R301.2 of the 2009 IRC, Stud specific gravity = 0.42.
- (b) Recommendations of siding manufacturer may vary.
- (c) APA Rated lap siding rated 16 oc and 24 oc shall be used with a maximum stud spacing of 16" o.c. and 24" o.c., respectively.

- (d) Hot-dip galvanized nails are recommended for most siding applications, see Siding Fasteners section of page 48 for more information.
- (e) Supported panel joints shall occur approximately along the centerline of framing with a minimum bearing of 1/2". Fasteners shall be located 3/8" from panel edges. Siding installed over two or more spans.
- (f) See Table 5, page 14, for nail dimensions.

TABLE 21A

MAXIMUM STUD SPACING: APA RATED SIDING (PANEL) APPLIED DIRECT-TO-STUDS OR STRUCTURAL SHEATHING

Siding Description	Minimum Performance Category or Span Rating	Maximum Stud Spacing (in.) for Vertical Rows of Nails	
		Parallel to Supports	Perpendicular to Supports
APA MDO GENERAL	3/8	16	24
	15/32	24	24
APA Rated Siding	16 oc	16	16 ^(a)
	24 oc	24	24

- (a) Stud spacing may be 24" o.c. for veneer-faced siding panels.

TABLE 21B

APA RATED SIDING (PANEL) APPLIED TO STRUCTURAL SHEATHING^{(a)(b)(c)(d)(e)}

APA Rated Panel Siding	Minimum Nail ^{(f)(g)}		Panel Nail Spacing		Maximum Wind Speed (mph)		
	Shank Diameter (in.)	Wall Stud Spacing (in. o.c.)	Edges ^(h) (in. o.c.)	Intermediate Supports (in. o.c.)	Wind Exposure Category		
				B	C	D	
3/8 Performance Category APA MDO GENERAL	0.120 ring shank	16	6	12	110	90	85
				6	125	105	90
APA Rated Siding 16 oc or 24 oc		24	6	12	90	NP	NP
				6	110	90	85

- (a) Table is based on wind pressures acting toward and away from building surfaces, at 30-ft height in wall Zone 5 (corners) with smallest effective area, per Section 6.4.2.2 of ASCE 7-05 and Section R301.2 of the 2009 IRC, Stud specific gravity = 0.42.
- (b) Recommendations of siding manufacturer may vary.
- (c) For use as wood structural panel wall bracing, the minimum fastener spacing of 6" o.c. at panel edges and 12" o.c. at intermediate supports shall be sufficient.

- (d) Hot-dip galvanized nails are recommended for most siding applications, see Siding Fasteners section on page 48 for more information.
- (e) Maximum stud spacing shall be in accordance with Table 21A.
- (f) Ring shank nail shall be used.
- (g) See Table 5, page 14, for nail dimensions.
- (h) Supported panel joints shall occur approximately along the centerline of framing with a minimum bearing of 1/2". Fasteners shall be located 3/8" from panel edges.

A single layer of wood structural panel siding, since it is strong and rack resistant, eliminates the cost of installing separate structural sheathing or diagonal wall bracing. Panel sidings are normally installed vertically, but may also be placed horizontally (long dimension across supports) if horizontal joints are blocked. Maximum stud spacings for both applications are given in Tables 19, 20 and 21.

When installing panel or lap siding over rigid foam insulation sheathing, drive the nails flush with the siding surface, but avoid over-driving, which can result in dimpling of the siding due to the compressible nature of foam sheathing.

Sidings are occasionally treated with water repellents or wood preservatives to improve finishing characteristics or moisture resistance for certain applications. If the siding has been treated, allowing the surface treatment to dry will avoid solvent or chemical reaction with the foam sheathing.

When rigid foam insulation sheathing is used, building codes also generally require installation of 1/2-inch gypsum wallboard, or other materials of the required thermal barrier rating, on the inside surface of the wall for fire protection.

See Figures 8 through 12 for panel and lap siding installation recommendations for the Sturd-I-Wall system or for siding installed over nailable sheathing. See *APA's Build A Better Home: Walls, Form A530*, for additional recommended details to avoid moisture penetration in walls.

All panel siding edges in Sturd-I-Wall construction should be backed with framing or blocking. Use nonstaining, non-corrosive nails as described in Tables 19, 20 and 21 to prevent staining the siding.

Where siding is to be applied at an angle, install only over wood structural panel sheathing.

Note: Gluing of siding to framing is not recommended due to the increased potential for panel buckling.

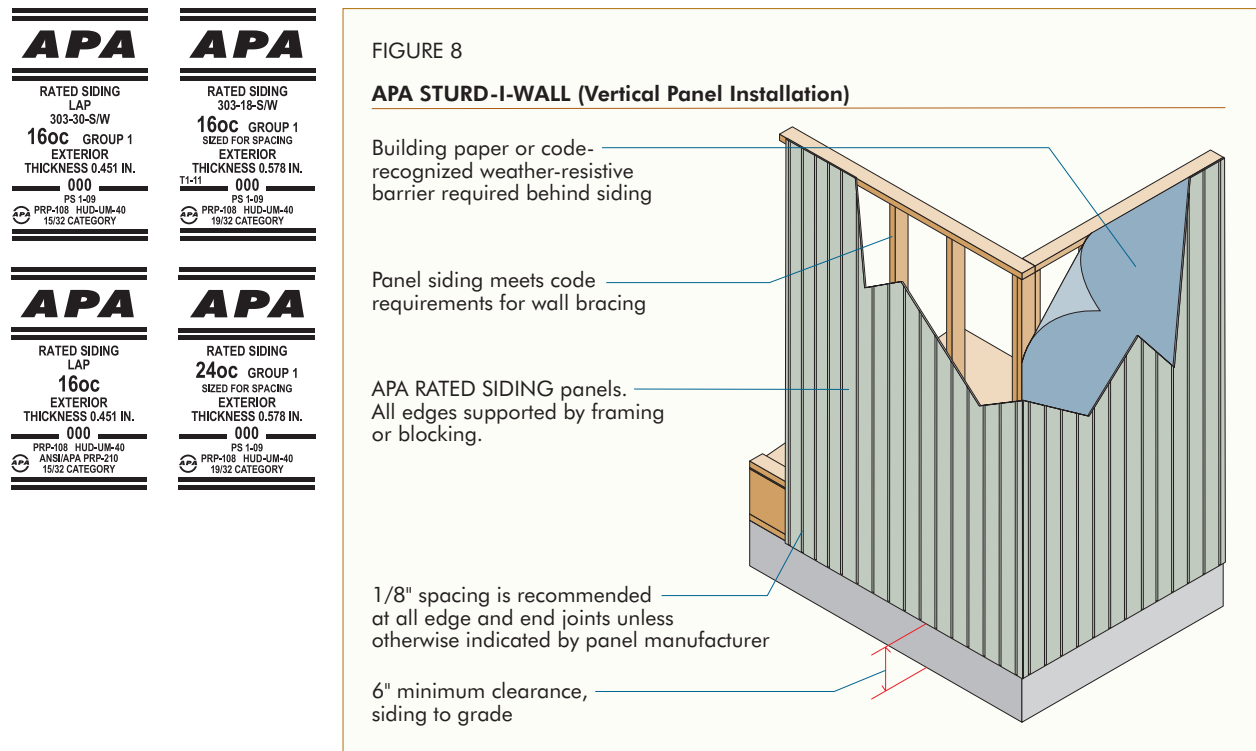

Siding Fasteners

Hot-dip galvanized nails are recommended for most siding applications. For best performance, stainless steel or aluminum nails should be considered. APA tests also show that electrically or mechanically galvanized steel nails appear satisfactory when plating meets or exceeds thickness requirements of **ASTM A641 Class 2** coatings, and is further protected by yellow chromate coating. Note that galvanized fasteners may react under wet conditions with the natural extractives of some wood species and may cause staining if left unfinished. Such staining can be minimized if the siding is finished in accordance with APA recommendations, or if the roof overhang protects the siding from direct exposure to moisture and weathering.

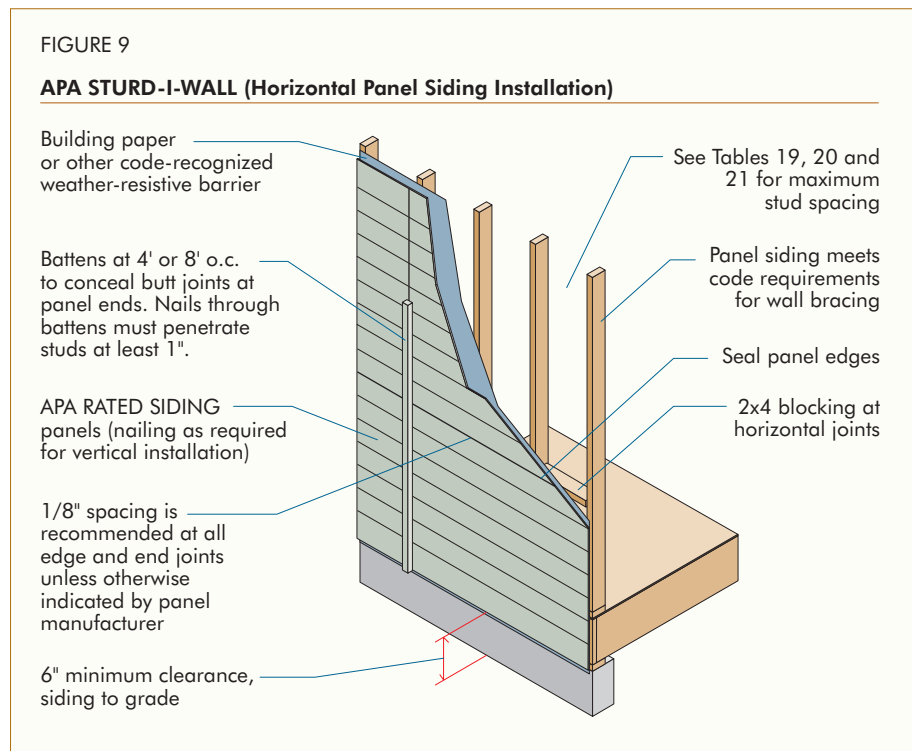

Wood Structural Panel Sheathing as a Nail Base for Siding

The recommendations in Tables 22 and 23 for panel and lap siding apply to siding installed over wood structural panel sheathing. Unless otherwise indicated in the local building code, nailable sheathing includes:

1. Nominal 1-inch boards with studs 16 or 24 inches o.c.
2. APA RATED SHEATHING panels with roof Span Rating of 24 inches or greater installed with strength axis either parallel or perpendicular to studs 16 or 24 inches o.c. (except 3-ply plywood panels must be applied with strength axis across studs when studs are spaced 24 inches o.c.).
3. APA RATED SHEATHING panels with roof Span Rating less than 24 inches installed with strength axis either parallel or perpendicular to studs 16 inches o.c. (except plywood panels 3/8 Performance Category or less must be applied with strength axis across studs).

Lap siding joints, if staggered, and panel siding joints may occur away from studs with wood structural panel sheathing.

Note: In addition to panel edge spacing and the use of straight studs, nailing sequence can also be a factor in maintaining a uniformly flat appearance of the finished wall. Installation procedure: First, position the panel, maintaining recommended edge spacing, and lightly tack at each corner. Install the first row of nails at the edge next to the preceding panel from top to bottom. Remove remaining tacking nails. Then nail the row at the first intermediate stud. Continue by nailing at the second intermediate stud, and finally, at the edge opposite the preceding panel. Complete the installation by fastening to the top and bottom plates.

For other fastener types, refer to Table 22. It provides the withdrawal resistance for a number of different fastener types (smooth-, ring- and screw-shank nails; wood screws and vinyl siding nails). Together with the [wind load tables](#) in the 2006 and 2009 International Residential Codes, [IRC Tables R301.2\(2\) and R301.2\(3\)](#), the attachment schedules for any combination of siding type, continuous wood structural panel sheathing, design wind speed and exposure can be determined. See [APA Technical Topic: Wood Structural Panels Used as Nailable Sheathing, Form TT-109](#) for more information including wind load tables and a sample calculation.

TABLE 22

FASTENER WITHDRAWAL LOADS FOR THE ATTACHMENT OF SIDING TO CONTINUOUS WOOD STRUCTURAL PANEL WALL SHEATHING^(a)

Ring-Shank Nails^{(b)(c)} Withdrawal Loads (lbf)								
Wall Sheathing Performance Category	Nail Diameter (in.)							
	0.091	0.094	0.097	0.113	0.120	0.128	0.135	0.148
3/8	31	32	33	38	41	43	46	50
7/16	36	37	38	45	48	51	53	59
15/32 and 1/2	39	40	41	48	51	54	57	63
19/32 and 5/8	49	51	52	61	64	69	73	80
23/32 and 3/4	59	61	63	74	78	83	88	96

Wood Screws^{(c)(d)} Withdrawal Loads (lbf)							
Wall Sheathing Performance Category	Screw Gauge/Diameter (in.)						
	#6	#7	#8	#9	#10	#12	#14
3/8	48	52	57	61	66	75	84
7/16	56	61	66	72	77	87	98
15/32 and 1/2	60	65	71	77	82	93	105
19/32 and 5/8	76	83	90	97	104	118	133
23/32 and 3/4	92	100	109	117	126	143	161

Smooth-Shank and Screw-Shank Nails^{(c)(e)} Withdrawal Loads (lbf)									Vinyl Siding Nails^{(c)(e)(f)} Withdrawal Loads	
Wall Sheathing Performance Category	Nail Diameter (in.)								Nail Diameter (in.)	
	0.092	0.099	0.113	0.120	0.128	0.131	0.135	0.148	0.122	0.125
3/8	8	8	9	10	11	11	11	12	10	10
7/16	9	10	11	12	13	13	13	14	12	12
15/32 and 1/2	10	10	12	13	13	14	14	16	13	13
19/32 and 5/8	12	13	15	16	17	17	18	20	16	17
23/32 and 3/4	15	16	18	19	21	21	22	24	20	20

- (a) Withdrawal capacities are based on the duration of load factor of 1.6 for wind applications. Adjustments for wet service and temperature are normally not required for attachment to the wood structural panel nailable sheathing.
- (b) For ring-shank nails, the withdrawal capacities (W) are based on specific gravities (G) of 0.70 in accordance with [APA TT-039](#) and $W = 1380 G^{2.5} D C_D t$, where: W = Withdrawal capacity (lbf), G = Specific Gravity, D = Nail diameter (in.), C_D = Duration of load factor (1.6 for wind loads), and t = wood structural panel thickness (in.).
- (c) Fasteners shall be long enough to fully penetrate wood structural panel sheathing by at least 1/4 inch.
- (d) For wood screws, the withdrawal capacities (W) are based on specific gravities (G) of 0.45 in accordance with [APA TT-051](#) and $W = 2850 G^2 D C_D t$, where: W = Withdrawal capacity (lbf), G = Specific Gravity, D = Nail diameter (in.), C_D = Duration of load factor (1.6 for wind loads), and t = wood structural panel thickness (in.).
- (e) For smooth-shank, screw-shank, and vinyl siding nails, the withdrawal capacities (W) are based on specific gravities (G) of 0.40 in accordance with [APA TT-039](#) and $W = 1380 G^{2.5} D C_D t$, where: W = Withdrawal capacity (lbf), G = Specific Gravity, D = Nail diameter (in.), C_D = Duration of load factor (1.6 for wind loads), and t = wood structural panel thickness (in.).
- (f) Vinyl siding nails shall have a head of at least 3/8 inch in diameter.

FIGURE 10

APA STURD-I-WALL (Horizontal Lap Siding Installation)^(a)

Building paper or other code-recognized weather-resistive barrier required

Leave 1/8" spacing and caulk vertical joints unless otherwise recommended by siding manufacturer

APA RATED SIDING (lap siding), maximum width 12". Minimum headlap 1".

6" minimum clearance, siding to grade

1-1/2"-wide starter strip, thickness to match lap siding

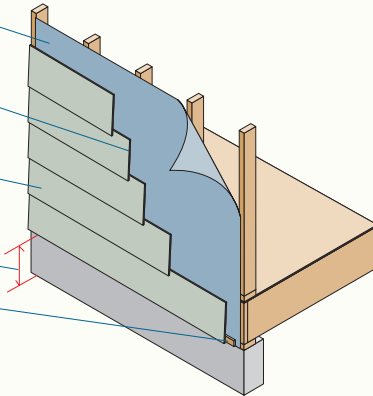

(a) For engineered shear wall segments or wall bracing requirements, use APA Rated Sheathing for wall sheathing under lap siding (see Figure 12). Other methods permitted by model building codes for braced wall segments may also be used.

FIGURE 11

APA RATED SIDING (PANEL SIDING) OVER WOOD STRUCTURAL PANEL SHEATHING

Building paper or other code-recognized weather-resistive barrier required

APA RATED SIDING panels applied over sheathing

6" minimum clearance, siding to grade

1/8" spacing is recommended at all edge and end joints unless otherwise indicated by panel manufacturer

Panel siding or APA RATED SHEATHING meets code requirement for wall bracing

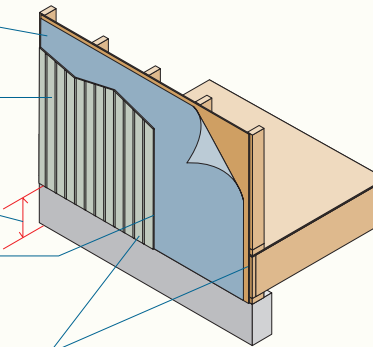

FIGURE 12

APA RATED SIDING (LAP SIDING) OVER WOOD STRUCTURAL PANEL SHEATHING

APA RATED SHEATHING meets code requirement for wall bracing

Building paper or other code-recognized weather-resistive barrier required

APA RATED SIDING (lap siding), maximum width 12". Minimum headlap 1".

Siding joints, if staggered may occur away from studs with nailable sheathing

6" minimum clearance, siding to grade

Leave 1/8" spacing and caulk vertical joints, unless otherwise recommended by siding manufacturer

1-1/2"-wide starter strip, thickness to match lap siding

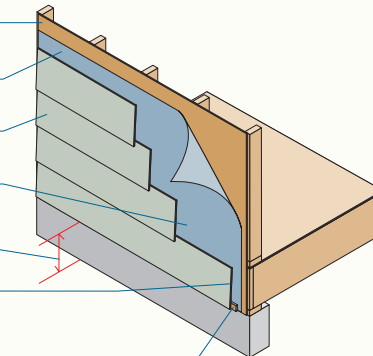

TABLE 23

APA RATED LAP SIDING APPLIED DIRECT-TO-STUDS OR OVER STRUCTURAL SHEATHING^{(a)(b)(c)}

Minimum Nail Shank Diameter ^(d) (in.)	Minimum Performance Category Lap Siding	Fastener Spacing (in.) ^(e)	Lap Siding Width (in.)	Maximum Wind Speed (mph)		
				Wind Exposure Category		
				B	C	D
0.113	3/8	6	6	130	110	100
			8	110	90	85
			12	85	NP	NP

(a) Table is based on wind pressures acting toward and away from building surfaces, at 30-ft height in wall Zone 5 (corners) with smallest effective area, per Section 6.4.2.2 of ASCE 7-05 and Section R301.2 of the 2009 IRC, Stud specific gravity = 0.42.

(b) Recommendations of siding manufacturer may vary.

(c) Hot-dip galvanized nails are recommended for most siding applications, see Siding Fasteners section on page 48 for more information.

(d) See Table 5, page 14, for nail dimensions.

(e) Fastener spacing at top edge of lap siding.

TABLE 24

APA RATED SHEATHING APPLIED DIRECT-TO-STUDS^{(a)(b)}

Minimum Nail ^(c)		Minimum Wood Structural Panel Span Rating	Minimum Panel Performance Category	Wall Stud Spacing (in.)	Panel Nail Spacing		Maximum Wind Speed (mph)		
Shank Diameter (in.)	Minimum Penetration (in.)				Edges (in. o.c.)	Field (in. o.c.)	Wind Exposure Category		
							B	C	D
0.113	1.5	24/0, Wall-16 and Wall-24	3/8	16	6	12	110	90	85
						6	110	100	90
0.131	1.75	24/16, Wall-24	7/16	16	6	12	130	110	105
						6	150	125	110
						12	150	125	110
						24 or less	110	90	85



(a) Panel strength axis parallel or perpendicular to supports. Three-ply plywood sheathing with studs spaced more than 16" on center shall be applied with panel strength axis perpendicular to supports.

(b) Table is based on wind pressures acting toward and away from building surfaces, at 30-ft height in wall Zone 5 (corners) with smallest effective area, per Section 6.4.2.2 of ASCE 7-05 and Section R301.2 of the 2009 IRC, Stud specific gravity = 0.42.

(c) See Table 5, page 14, for nail dimensions.

APA Panel Wall Sheathing

APA RATED SHEATHING meets building code wall sheathing requirements for wind pressures and wall bracing. Even when foam or other nonstructural sheathing is used, APA RATED SHEATHING corner bracing panels (Figure 14) of the same thickness meet code wall bracing requirements. Installation recommendations are given in Figure 13 and Table 24.

 RATED SHEATHING 24/0 SIZED FOR SPACING EXPOSURE 1 THICKNESS 0.354 IN. 000 PS 2-10 SHEATHING PRP-108 HUD-UM-40 3/8 CATEGORY	 RATED SHEATHING 24/16 SIZED FOR SPACING EXPOSURE 1 THICKNESS 0.418 IN. 000 PS 2-10 SHEATHING PRP-108 HUD-UM-40 7/16 CATEGORY	 RATED SHEATHING STRUCTURAL I 32/16 SIZED FOR SPACING EXPOSURE 1 THICKNESS 0.451 IN. 000 PS 1-09 C-D PRP-108 15/32 CATEGORY
--	---	--

Recommended wall sheathing spans with brick veneer or masonry are the same as those for panel sheathing (see Table 24). See Figure 15 for installation recommendations.

Panel recommendations for preframed wall sections are the same as for built-in-place walls.

Note: To minimize the potential for panel buckling, gluing of wall sheathing to framing is not recommended, except when recommended by the adhesive manufacturer for wall sheathing that already has been permanently protected by siding.

FIGURE 13
APA PANEL WALL SHEATHING

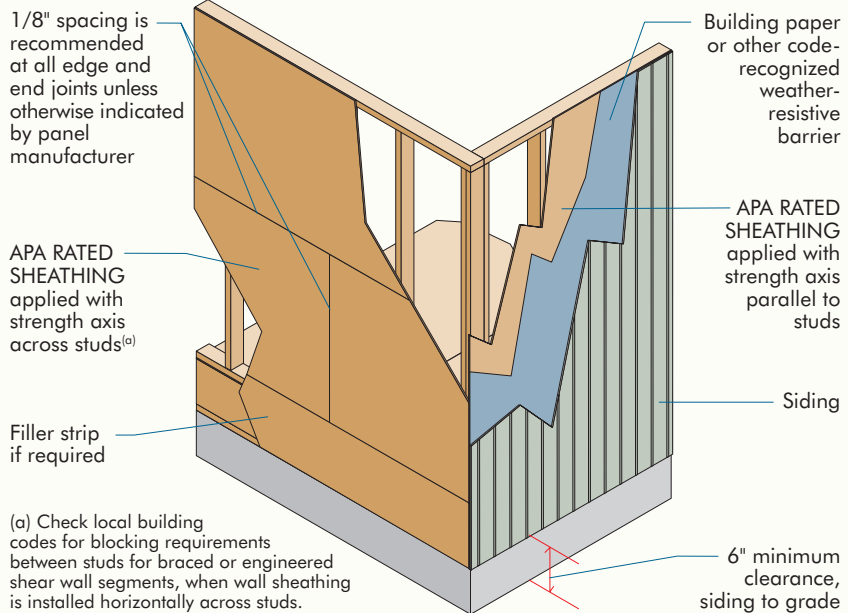

FIGURE 14
APA PANEL CORNER BRACING

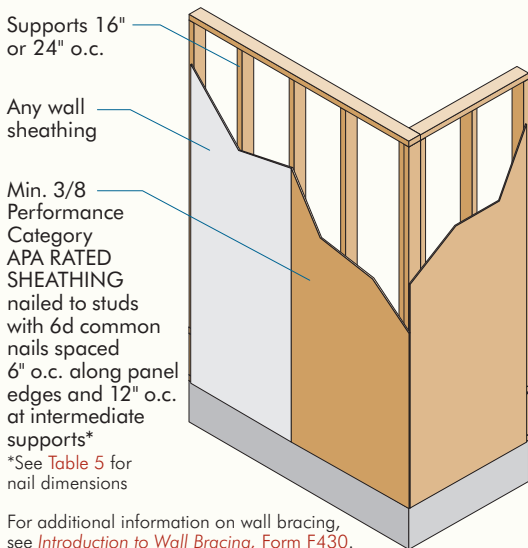
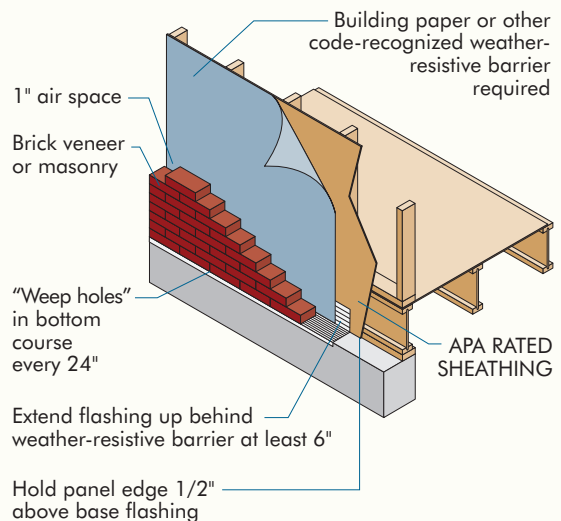

FIGURE 15
BRICK VENEER OVER APA PANEL SHEATHING



APA Sheathing Under Stucco

Greater stiffness is recommended for wall sheathing when stucco is to be applied. To increase stiffness, apply the long panel dimension or strength axis across studs. Blocking or a plywood cleat is recommended at horizontal joints. Blocking is required for shear wall and wall bracing applications. For panel recommendations applied horizontally or vertically, see Table 25.

Siding Joint Details

The siding joint details in Figure 17 are based on the use of APA trademarked siding. Nailing of wood structural panel siding along both edges of shiplap joints (“double nailing”), as shown, is required for shear walls or those wall segments that must meet bracing requirements. Double nailing is recommended for all other applications as well to provide maximum wall strength and moisture protection.

Where caulks or joint sealants are indicated, consider the various types available such as urethane, plasticized acrylic latex, butyl and polysulfide. Check with the manufacturer of the caulk or sealant to determine suitability for the intended application and compatibility with coatings and other building materials such as vinyl and aluminum.

In some cases, a foam backer rod or other type filler material may be used behind the sealants as recommended by the manufacturer. For best results in other cases, apply caulking to framing at panel edges before installing the siding panel; or apply a bead of caulk along the panel edge before installing the next panel. A 1/8-inch space is recommended at all edge and end joints unless otherwise indicated by panel manufacturer. If caulk is to be used, also check with caulk manufacturer for recommended edge spacing. Nails through battens or other wood trim must penetrate at least 1 inch into studs. Nail panel siding 6 inches o.c. along edges and 12 inches o.c. at intermediate supports. To prevent staining of siding, use hot-dip galvanized, aluminum, or other nonstaining nails as described on page 48.

Siding is often fully exposed to weather and thus has increased susceptibility to elevated moisture conditions. Although siding will periodically experience moisture contents above the threshold value needed to support decay, wood-based siding products have a good history of performance because they dry below this threshold value before decay can initiate. If trim is installed around siding, be sure that it doesn't trap moisture or reduce the drying ability of the wood. Trim that is applied incorrectly can lead to long-term moisture accumulation that causes decay.

Apply flashing or other means of protection over end grain of siding to minimize water absorption.

TABLE 25

RECOMMENDED THICKNESS AND SPAN RATING FOR APA PANEL WALL SHEATHING FOR STUCCO EXTERIOR FINISH

Stud Spacing (in.)	Panel Orientation ^(a)	APA Rated Sheathing ^(b)	
		Minimum Performance Category	Minimum Span Rating
16	Horizontal ^(c)	3/8	24/0
	Vertical	7/16 ^(d) 15/32 ^(e) , 1/2 ^(e)	24/16 32/16
24	Horizontal ^(c)	7/16	24/16
	Vertical	19/32 ^(e) , 5/8 ^(e)	40/20

- (a) Strength axis (typically the long panel dimension) perpendicular to studs for horizontal application; or parallel to studs for vertical application.
- (b) Recommendations apply to all-veneer plywood or oriented strand board (OSB) except as noted.
- (c) Blocking recommended between studs along horizontal panel joints.
- (d) Structural I Rated Sheathing (OSB).
- (e) OSB or 5-ply/5-layer plywood.

FIGURE 16

STUCCO OVER APA PANEL SHEATHING

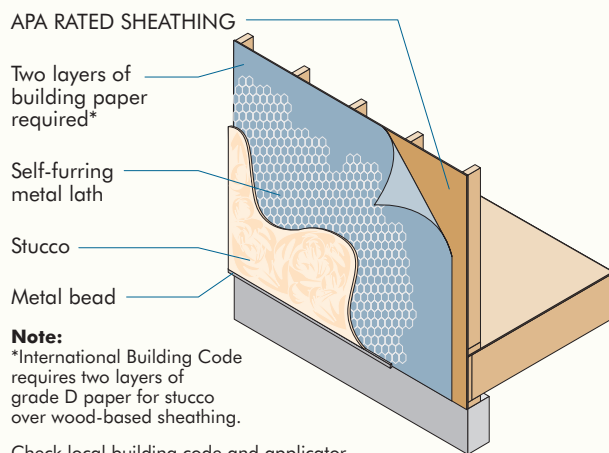

Note:
*International Building Code requires two layers of grade D paper for stucco over wood-based sheathing.
Check local building code and applicator for specific requirements.

FIGURE 17

TYPICAL PANEL SIDING JOINT DETAILS

(Note: Water-resistant barrier [building paper or house wrap] is required behind siding.)

VERTICAL WALL JOINTS

Butt

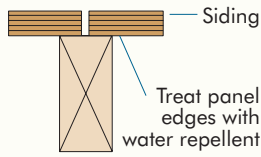

Shiplap

Reverse Board and Batten

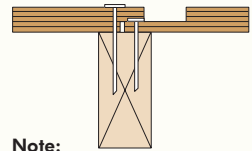

T1-11 & Channel Groove

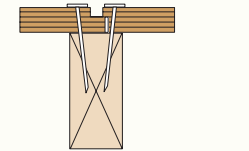

Note:

Nailing of both panel edges along shiplap joint is recommended. The "double nailing" is required when wall segment must meet wall bracing or engineered shear wall requirements.

Vertical Batten

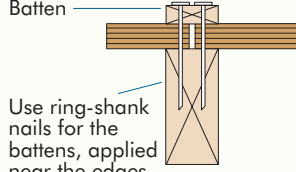

Use ring-shank nails for the battens, applied near the edges in two staggered rows

VERTICAL INSIDE & OUTSIDE CORNER JOINTS

Butt & Caulk

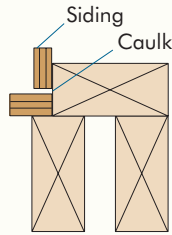

Corner Board Lap Joints

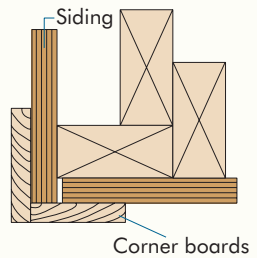

Lap Siding (APA Sturd-I-Wall)

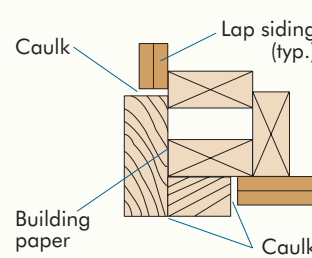
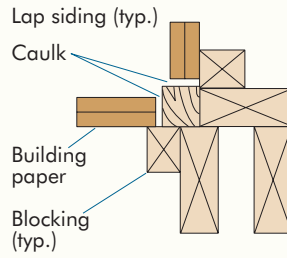

HORIZONTAL WALL JOINTS

Butt & Flash

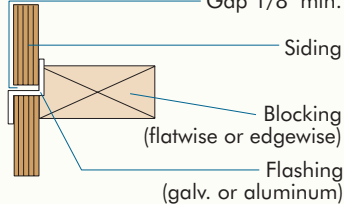

Lap

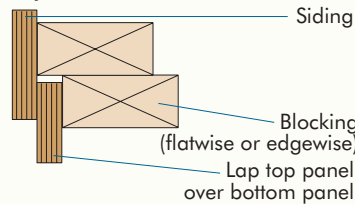

Shiplap

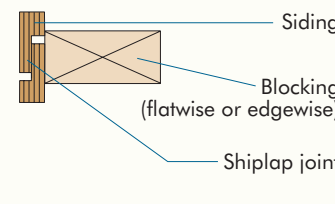

HORIZONTAL BELTLINE JOINTS

(For multistory buildings, when conventional lumber floor joists and rim boards are used, make provisions at horizontal joints for shrinkage of framing, especially when applying siding direct to studs.)

Jog Exterior Stud Line

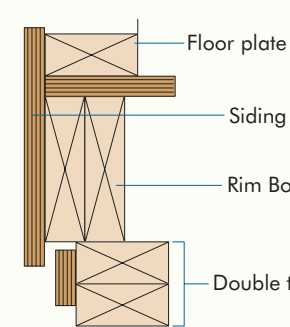

Band Board Over Panel Filler

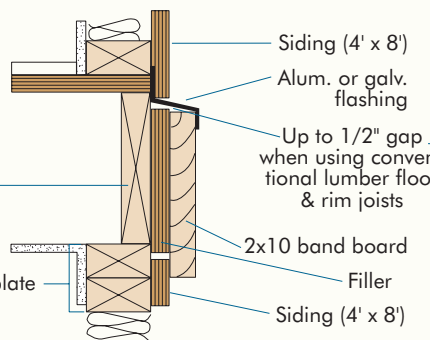

Band Board In Relief

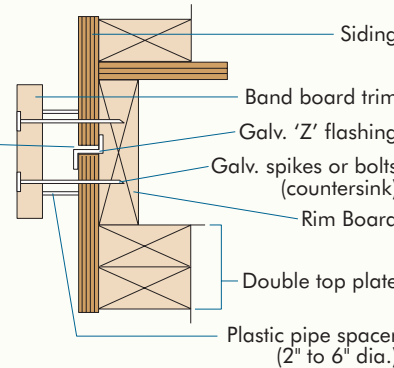

WINDOW DETAILS

(For window details, see *Build A Better Home: Walls, Form A530.*)

APA Rated Siding Patterns and Grades

APA RATED SIDING, including 303 plywood siding, is available in a wide variety of surface textures and patterns. For descriptions of siding surface patterns and thicknesses, refer to *APA Product Guide: APA Performance Rated Sidings, Form E300*. Actual dimensions of groove spacing, width and depth may vary with the manufacturer. Where the characteristics of a particular wood species are desired, specify by grade and species preference.

In order to help specifiers select the most appropriate siding appearance for any particular job, APA 303 plywood sidings are also identified by a face grading system. There are four basic siding classifications within the system – Special Series 303, 303-6, 303-18 and 303-30. Each class, as shown in Table 26, is further divided into grades according to categories of repair and appearance characteristics.

Finishing Plywood for Exterior Exposure

Care and Preparation

Plywood should be stored and handled with care to avoid damaging before finishing. Storage in a cool, dry place out of sunlight and weather is best. If left outdoors, straps on bundles should be loosened or cut and the plywood covered. Allow good air circulation to prevent moisture condensation and possible mold growth.

Edge Sealing

Moisture enters the end grain of plywood or other wood-based products faster than through the surface. Consequently, edges and ends of APA RATED SIDING panels or lap siding should be sealed. Although edge sealers are not necessarily moisture-proof or permanently durable, they help to minimize sudden changes in moisture content in the siding, due to weather.

APA RATED SIDING may be edge sealed at the factory. If the siding is not factory-sealed, it can be sealed quickly at the job site while the panels or lap siding pieces are still in a stack. Edges or ends cut during construction should be resealed.

Siding to be finished with a semitransparent or solid-color stain can be edge sealed with a liberal application of a paintable, water-repellent sealer. If the siding is to be painted, apply sealer to edges using the same paint primer that will be used on the surface. Horizontal edges, particularly lower drip edges of siding, should be carefully edge-sealed because of their greater wetting exposure.

TABLE 26

APA 303 SIDING FACE GRADES^(a)

303 Series Plywood Siding Grades	Type of Patch	
	Wood	Synthetic
303-OC	Not permitted	Not permitted
303-OL	Not applicable for overlays	
303-NR	Not permitted	Not permitted
303-SR	Not permitted	Permitted as natural-defect shape
303-6-W	Limit 6	Not permitted
303-6-S	Not permitted	Limit 6
303-6-S/W	Limit 6 – any combination	
303-18-W	Limit 18	Not permitted
303-18-S	Not permitted	Limit 18
303-18-S/W	Limit 18 – any combination	
303-30-W	Limit 30	Not permitted
303-30-S	Not permitted	Limit 30
303-30-S/W	Limit 30 – any combination	

(a) All panels except 303-NR allow restricted minor repairs such as shims. These and such other face appearance characteristics as knots, knotholes, splits, etc., are limited by both size and number in

accordance with panel grades, 303-OC being most restrictive and 303-30 being least. Multiple repairs are permitted only on 303-18 and 303-30 panels. Patch size is restricted on all panel grades.

Finishing

APA RATED SIDING may be finished with a variety of products such as semi-transparent stains, solid-color stains or paint systems. The recommended finishes depend on the type of siding product, and whether it has an overlaid surface.

Oil-based, semitransparent stains may be used on certain veneer-faced siding products as detailed in Table 27. Solid-color stains may be used on most APA RATED SIDING products and usually provide better protection. In general, however, best overall performance on APA RATED SIDING products can be achieved with an all-acrylic latex paint system.

For overlaid siding, any top-quality exterior house paint system formulated for wood performs satisfactorily. Solid-color stains may also be used on overlaid sidings, although some manufacturers recommend only acrylic latex formulations. For specific recommendations on finishing OSB siding products, consult the siding manufacturer.

Table 27 provides a summary of finishing recommendations for APA 303 Siding face grades. For complete information, refer to *APA Product Guide: Performance Rated Sidings, Form E300*.

Semitransparent Stains (oil-based only)

Oil-based semitransparent stains emphasize grain patterns, texture and natural characteristics in the wood. They may be used on plywood face grades 303-OC, 303-NR and 303-6-W. It is the only finish recommended for use over brushed plywood. Other 303 face grades should not be finished with semitransparent stains unless specifically recommended by the panel manufacturer.

Solid-Color Stains (oil or all-acrylic latex)

An opaque or solid-color stain obscures color differences in the wood and between repairs and surrounding wood. This is often a satisfactory finishing system, therefore, where semitransparent stains are unsuitable. Wood grain is also muted with solid-color stains but wood surface textures usually remain evident. When in question, the finish should be applied to a representative sample in order to demonstrate the finished appearance.

Solid-color stains are particularly recommended for grades 303-6-S and 303-6-S/W, as well as 303-18 and 303-30 with any type of patch.

TABLE 27

APA 303 SIDING FINISHING RECOMMENDATIONS

303 Series Plywood Siding Grades	STAINS		PAINTS
	Semitransparent (oil)	Solid Color (oil or latex) ^(a)	Minimum 1 primer plus 1 topcoat (acrylic latex)
303-OC	(b)	(b)	(b)
303-OL	Not Recommended	(d)	(b)
303-NR	(b)	(e)	(e)
303-SR	(c)	(e)	(e)
303-6-W	(b)	(b)	(b)
303-6-S	(c)	(b)	(b)
303-6-S/W	(c)	(b)	(b)
303-18-W	(c)	(b)	(b)
303-18-S	(c)	(b)	(b)
303-18-S/W	(c)	(b)	(b)
303-30-W	(c)	(b)	(b)
303-30-S	(c)	(b)	(b)
303-30-S/W	(c)	(b)	(b)

(a) Except for overlaid panels, use a stain-resistant primer with light-colored latex stains, since the wood extractives may cause a discoloration of the finish.

(b) Recommended with provisions given in text.

(c) Should not be finished with semitransparent stain unless specifically recommended by the panel manufacturer.

(d) Some panel manufacturers recommend only acrylic latex formulations. Consult the manufacturer's recommendations.

(e) Only acrylic latex formulations are recommended when solid-color stains or paint systems are applied over open voids.

Paints (all-acrylic latex)

Top-quality acrylic latex house paint systems are recommended for all APA Rated Siding, except brushed plywood. If house paint is used on plywood siding, an all-acrylic latex paint system consisting of at least one stain-blocking prime coat and an all-acrylic latex topcoat is recommended. For extractive staining woods, some house paint systems utilize an oil-alkyd primer. Others use up to two coats of a stain-blocking acrylic latex primer. These latter systems help to reduce face-checking and generally offer superior performance. A paint finish tends to mask the textured plywood surface more than either semitransparent or solid-color stains. On the other hand, a top-quality acrylic latex paint system provides the most durable finish.

Grade 303-OL may be finished with any top-quality exterior paint system – primer and companion topcoat – formulated for wood.

Field Application of Finish

Proper surface preparation is important for good performance of finishes on any surface. Remove dirt and loose wood fibers with a stiff nonmetallic bristle brush. Mildew may be removed with a solution of 1/4 part household bleach to 3/4 part warm water. Be sure to rinse thoroughly after application of bleach.

Finishes should be applied as soon as possible after installation of the siding. Weathering of unprotected wood can cause surface damage in as little as two to four weeks. Apply finishes during favorable weather conditions. As a rule of thumb, finishes should not be applied when the outside air temperature is expected to drop below 50° F (10° C) within 24 hours for latex finishes, or 40° F (5° C) for oil-based finishes. However, recommendations of individual manufacturers may vary and should always be followed. Wood surfaces should be clean and dry, although extremely dry surfaces should be dampened slightly when applying latex finishes.

Use only top-quality finishes and application equipment. Finishes should be applied according to the spread rates recommended by the manufacturer. Textured surfaces may require up to twice as much finish as smooth surfaces. The first coat should be applied by brush. If spray equipment is used to apply the finish, then the finish should be either back-brushed or back-rolled while it is still wet. Subsequent coats of finish may be applied by any conventional means.

Interior Paneling

APA Rated Siding panels lend themselves to a number of decorative surface treatments for attractive interior paneling and accent walls. (See Figures 18 and 19.) Such treatments include saw-textured, brushed, embossed and grooved. Let APA panels acclimatize to room temperature and humidity conditions for several days prior to attachment to the wall. This can be accomplished by placing the panels on edge with space between each panel to allow air to circulate freely over both sides. Preservative treatment of furring or studs is recommended when they are attached to masonry or concrete exterior walls and to any uncured concrete wall. Also, in these instances, install a 4-mil polyethylene vapor retarder between the paneling and the furring or studs and insulated exterior walls. Support and nail spacing recommendations are given in Table 28. Recommendations apply to all species groups.

TABLE 28

INTERIOR PANELING

Panel Performance Category	Maximum Support Spacing (in.)	Nail Size (Use casing or finishing nails) ^(c)	Maximum Nail Spacing (in.)	
			Panel Edges	Intermediate Supports
1/4	16 ^(a)	4d	6	12
5/16	16 ^(b)	6d	6	12
11/32 - 1/2	24	6d	6	12
19/32 - 3/4	24	8d	6	12
Texture 1-11	24	8d	6	12

(a) Can be 20 inches if strength axis of paneling is across supports.

(c) See Table 5, page 14, for nail dimensions.

(b) Can be 24 inches if strength axis of paneling is across supports.

FIGURE 18

PANELING NEW INTERIOR WALLS

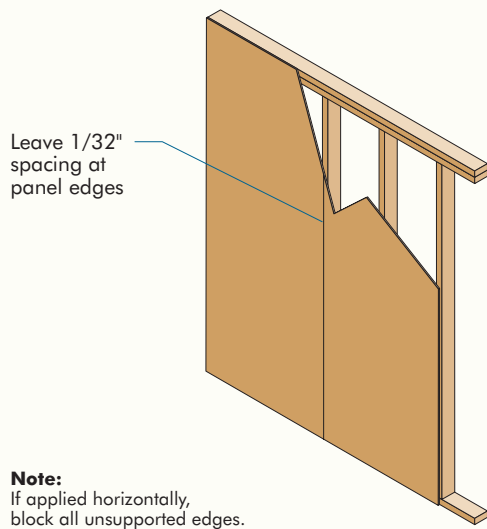
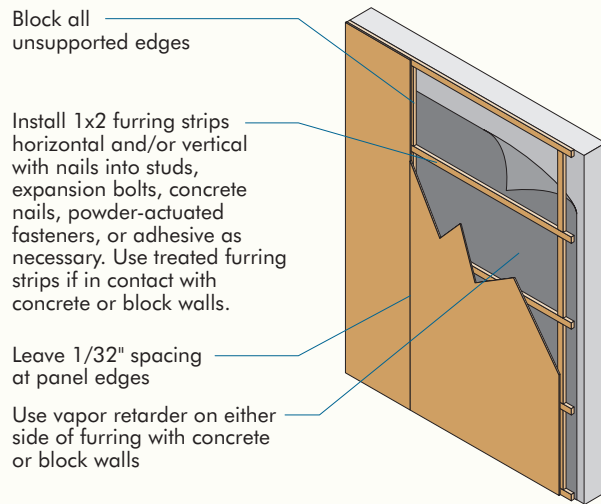

FIGURE 19

PANELING EXISTING INTERIOR WALLS



Panel Backing

Wood structural panels are excellent backing for wall coverings such as rare hardwoods, vinyl surfaces and decorative fabrics. Panels with Performance Categories smaller than 15/32 should be applied with strength axis perpendicular to studs and with 2x4 blocking at horizontal edges. Thicker panels may be applied with strength axis parallel to studs. For thin coverings subject to telegraphing of underlying surface texture, only sanded plywood is recommended. Plywood panels should have C-Plugged or better faces. Use 6d nails spaced 6 inches on center at panel edges and 12 inches on center at intermediate supports. A 1/16-inch space should be left between panels. Where moisture may be present, use nonstaining nails and either Exposure 1 or Exterior type panels. A 1/4-inch clearance is recommended at the bottom edge of the panels.

Wood Structural Panel Wall Bracing and Shear Walls

Wood structural panel wall bracing and shear walls are used to resist racking forces caused by lateral loads from wind or seismic events. Wall bracing and shear walls serve the same purpose, to resist wall-racking forces, but they have distinct differences as explained on [page 60](#). While all of the wall systems presented here will provide sufficient wall bracing strength under normal conditions in residential and light-frame construction, engineered shear walls may be desirable or required in areas of the country with frequent seismic activity or high wind loads. Shear walls are also integral to commercial and industrial construction.

TABLE 29
ALLOWABLE SHEAR (POUNDS PER FOOT) FOR APA PANEL SHEAR WALLS WITH FRAMING OF DOUGLAS-FIR, LARCH, OR SOUTHERN PINE^(a) FOR WIND^{(b)(c)(d)(e)(f)} OR SEISMIC^{(c)(d)(e)(g)} LOADING

Panel Grade	Minimum Nominal Panel Thickness (in.)	Minimum Nail Penetration in Framing (in.)	Panels Applied Direct to Framing				Panels Applied Over 1/2" or 5/8" Gypsum Sheathing						
			Nail Size (common or galvanized box) ^(h)	Nail Spacing at Panel Edges (in.)				Nail Size (common or galvanized box)	Nail Spacing at Panel Edges (in.)				
				6	4	3	2 ⁽ⁱ⁾		6	4	3	2 ⁽ⁱ⁾	
APA STRUCTURAL I grades	3/8			230 ⁽ⁱ⁾	360 ⁽ⁱ⁾	460 ⁽ⁱ⁾	610 ⁽ⁱ⁾						
	7/16	1-3/8	8d	255 ⁽ⁱ⁾	395 ⁽ⁱ⁾	505 ⁽ⁱ⁾	670 ⁽ⁱ⁾	10d	280	430	550 ⁽ⁱ⁾	730	
	15/32			280	430	550	730						
APA RATED SHEATHING; APA RATED SIDING ^(m) and other APA grades except species Group 5	15/32	1-1/2	10d	340	510	665 ⁽ⁱ⁾	870						
	5/16 or 1/4 ^(k)			180	270	350	450	8d	180	270	350	450	
	3/8	1-1/4	6d	200	300	390	510		200	300	390	510	
	3/8			220 ⁽ⁱ⁾	320 ⁽ⁱ⁾	410 ⁽ⁱ⁾	530 ⁽ⁱ⁾						
	7/16	1-3/8	8d	240 ⁽ⁱ⁾	350 ⁽ⁱ⁾	450 ⁽ⁱ⁾	585 ⁽ⁱ⁾	10d	260	380	490 ⁽ⁱ⁾	640	
	15/32			260	380	490	640						
15/32	1-1/2	10d	310	460	600 ⁽ⁱ⁾	770							
APA RATED SIDING ^(m) and other APA grades except species Group 5	19/32			340	510	665 ⁽ⁱ⁾	870						
			Nail Size (galvanized casing)					Nail Size (galvanized casing)					
	5/16 ^(k)	1-1/4	6d	140	210	275	360	8d	140	210	275	360	
	3/8	1-3/8	8d	160	240	310	410	10d	160	240	310 ⁽ⁱ⁾	410	

- (a) For framing of other species: (1) Find specific gravity for species of lumber in the AF&PA National Design Specification (NDS). (2) For common or galvanized box nails, find shear value from table above for nail size for actual grade. (3) Multiply value by the following adjustment factor: Specific Gravity Adjustment Factor = [1 - (0.5 - SG)], where SG = specific gravity of the framing. This adjustment shall not be greater than 1.
- (b) For wind load applications, the values in the table above shall be permitted to be multiplied by 1.4.
- (c) All panel edges backed with 2-inch nominal or wider framing. Install panels either horizontally or vertically. Space nails maximum 6 inches o.c. along intermediate framing members for 3/8-inch and 7/16-inch panels installed on studs spaced 24 inches o.c. For other conditions and panel thicknesses, space nails maximum 12 inches o.c. on intermediate supports. Fasteners shall be located 3/8 inch from panel edges.
- (d) Where panels applied on both faces of a wall and nail spacing is less than 6 inches o.c. on either side, panel joints shall be offset to fall on different framing members, or framing shall be 3-inch nominal or thicker at adjoining panel edges and nails on each side shall be staggered.
- (e) Galvanized nails shall be hot-dip or tumbled.
- (f) For shear loads of normal or permanent load duration as defined by the AF&PA NDS, the values in the table above shall be multiplied by 0.63 or 0.56 respectively.
- (g) In Seismic Design Category D, E, or F, where shear design values exceed 350 pounds per lineal foot, all framing members receiving edge nailing from abutting panel edges shall not be less than a single 3-inch nominal member, or two 2-inch nominal members fastened together to transfer the design shear value between framing members. Wood structural panel joint and sill plate nailing shall be staggered in all cases. See IBC or AF&PA Special Design Provisions for Wind and Seismic (SDPWS) for sill plate size and anchorage requirements.
- (h) See Table 5, page 14, for nail dimensions.
- (i) Framing at adjoining panel edges shall be 3-inch nominal or wider, and nails shall be staggered where nails are spaced 2 inches o.c. Check local code for variations of these requirements.
- (j) Allowable shear values are permitted to be increased to values shown for 15/32-inch sheathing with same nailing provided (1) studs are spaced a maximum of 16 inches on center, or (2) panels are applied with long dimension across studs.
- (k) 3/8-inch or APA RATED SIDING 16 oc is minimum recommended when applied direct to framing as exterior siding.
- (l) Framing at adjoining panel edges shall be 3-inch nominal or wider, and nails shall be staggered where 10d nails (3" x 0.148") having penetration into framing of more than 1-1/2 inches are spaced 3 inches o.c. Check local code for variations of these requirements.
- (m) Values apply to all-veneer plywood APA RATED SIDING panels only. Other APA RATED SIDING panels may also qualify on a proprietary basis. APA RATED SIDING 16 oc plywood may be 11/32 inch, 3/8 inch or thicker. Thickness at point of nailing on panel edges governs shear values.

Typical Layout for Shear Walls

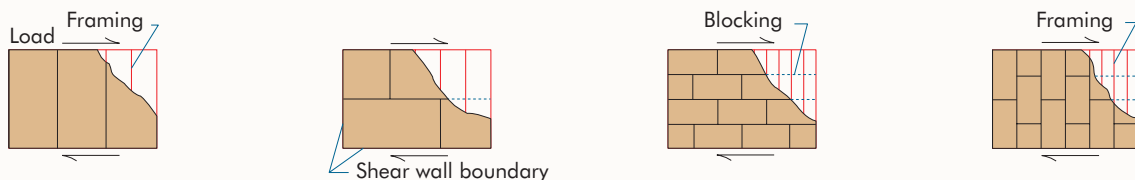

Wall Bracing

Wall bracing is typically a part of conventional prescriptive construction as found in [2009 International Building Code \(IBC\) Section 2308](#) or the [International Residential Code \(IRC\) Chapter 6](#). Wall bracing is prescribed in a how-to format, and braced walls generally do not require hold down devices or have significant nailing requirements. Usually, there is no engineering required when using wall bracing since the “solution” is prescribed. For structures or portions of them that do not meet the prescribed construction parameters in the IBC or IRC, engineered design is required.

Meeting the bracing requirements is easy when using wood structural panel wall sheathing because of its inherent strength. More information is available at www.wallbracing.org and in the following APA publications:

- [Introduction to Wall Bracing, Form F430](#)
- [Brace Walls with Wood, Form G440](#)

Shear Walls

The engineered version of wall bracing is a shear wall. Shear walls are designed by an engineer to resist the specific forces determined by engineering analysis. Shear walls have specific design values depending on their construction, fastener spacing, fastener size, sheathing thickness and framing species. [Table 29](#) shows the Allowable Stress Design values for single-sided sheathed wood structural panel shear walls. Shear walls are also permitted to be designed to account for openings and with both sides of the wall sheathed. They usually require hold downs to resist overturning of wall segments, as shown in Figure 20. More information on designing with shear walls is available in the APA publication [Design/Construction Guide: Diaphragms and Shear Walls, Form L350](#).

Either APA RATED SHEATHING or all-veneer plywood APA RATED SIDING (and other APA RATED SIDING panels that qualify on a proprietary basis) can be used in shear wall design. The data presented here give maximum shears for walls with APA RATED SHEATHING, with plywood APA RATED SIDING installed directly to studs (APA Sturd-I-Wall), and with panels applied over gypsum sheathing for walls required to be fire-rated from the outside.

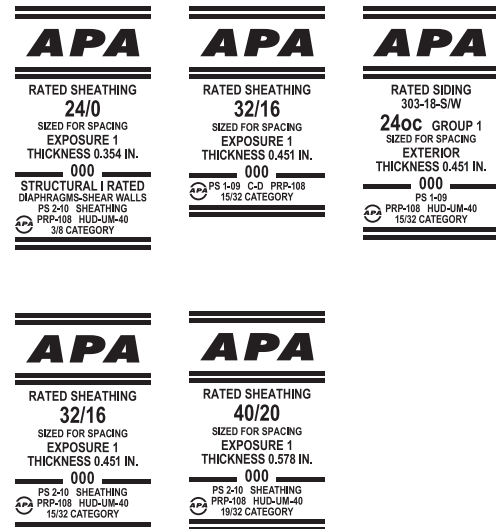
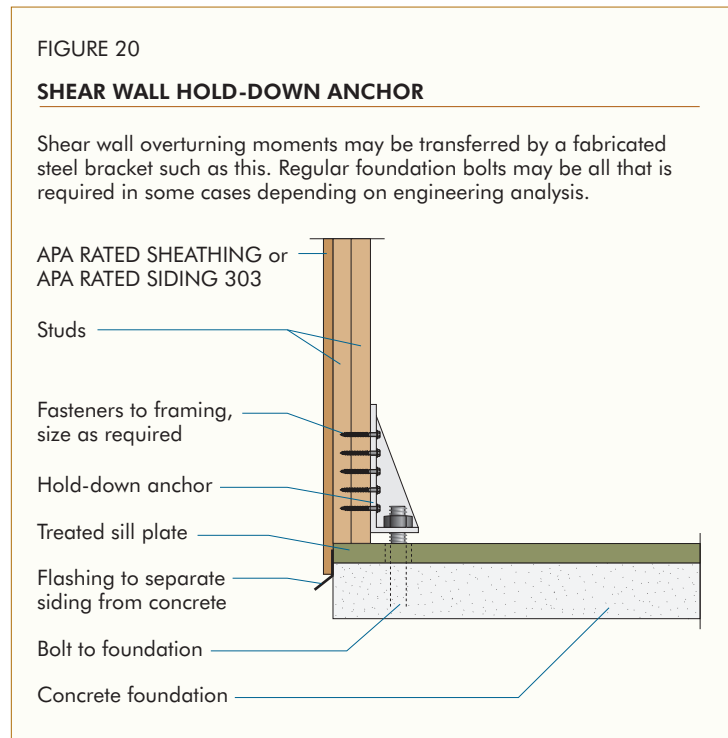



ROOF CONSTRUCTION

APA Panel Roof Sheathing

The recommendations for roof sheathing in Table 30 apply to APA RATED SHEATHING Exposure 1 or Exterior, APA STRUCTURAL I RATED SHEATHING Exposure 1 or Exterior and APA RATED STURD-I-FLOOR Exposure 1 or Exterior. Uniform load deflection limits are 1/180 of span under live load plus dead load, and 1/240 under live load

TABLE 30

RECOMMENDED UNIFORM ROOF LIVE LOADS FOR APA RATED SHEATHING^(a) AND APA RATED STURD-I-FLOOR WITH STRENGTH AXIS PERPENDICULAR TO SUPPORTS^(b)

Panel Span Rating	Minimum Panel Performance Category	Maximum Span (in.)		Allowable Live Loads (psf) ^(d)						
		With Edge Support ^(c)	Without Edge Support	Spacing of Supports Center-to-Center (in.)						
				12	16	20	24	32	40	48
APA RATED SHEATHING ^(a)										
12/0	3/8	12	12	30						
16/0	3/8	16	16	70	30					
20/0	3/8	19.2	19.2	120	50	30				
24/0	3/8	24	19.2 ^(e)	190	100	60	30			
24/16	7/16	24	24	190	100	65	40			
32/16	15/32	32	28	300	165	110	65	30		
40/20	19/32	40	32	—	275	195	120	60	30	
48/24	23/32	48	36	—	—	270	175	95	45	30
60/32 ^(f)	7/8	60	40	—	—	—	305	165	100	70
60/48 ^(f)	1-1/8	60	48	—	—	—	305	165	100	70
APA RATED STURD-I-FLOOR ^(g)										
16 oc	19/32	24	24	185	100	65	40			
20 oc	19/32	32	32	270	150	100	60	30		
24 oc	23/32	48	36	—	240	160	100	50	30	20
32 oc	7/8	48	40	—	—	295	185	100	55	35
48 oc	1-3/32	60	48	—	—	—	290	160	100	65

(a) Includes APA RATED SHEATHING/CEILING DECK.

(b) Applies to APA RATED SHEATHING and APA RATED STURD-I-FLOOR panels 24 inches or wider applied over two or more spans.

(c) Tongue-and-groove edges, panel edge clips (one midway* between each support, except two equally spaced between supports 48 inches on center or greater), lumber blocking, or other. For low slope roofs, see Table 31.

(d) 10 psf dead load assumed.

(e) 19.2 inches for Performance Category 3/8 and 7/16 panels. 24 inches for Performance Category 15/32 and 1/2 panels.

(f) Check with supplier for availability.

(g) Also applies to C-C Plugged grade plywood.

*No established tolerance.

only. Special conditions, such as heavy concentrated loads, may require constructions in excess of these minimums, or allowable live loads may have to be decreased for dead loads greater than 10 psf, such as tile roofs. **Panels are assumed continuous over two or more spans with the long dimension or strength axis across supports.**

Good performance of built-up, single-ply, or modified bitumen roofing applied on low slope roofs requires a stiffer deck than does prepared roofing applied on pitched roofs. Although APA Span-Rated panels used as roof sheathing at maximum span are adequate structurally, an upgraded system is recommended for low slope roofs. Table 31 provides recommended maximum spans for low slope roof decks. Recommended live loads can be determined

TABLE 31

RECOMMENDED MAXIMUM SPANS FOR APA PANEL ROOF DECKS FOR LOW SLOPE ROOFS^(a) (Panel strength axis perpendicular to supports and continuous over two or more spans)

Grade	Minimum Panel Performance Category	Minimum Span Rating	Maximum Span (in.)	Panel Clips Per Span ^(b) (number)
APA RATED SHEATHING	15/32	32/16	24	1
	19/32	40/20	32	1
	23/32	48/24	48	2
	7/8	60/32	60	2
APA RATED STURD-I-FLOOR	19/32	20 oc	24	1
	23/32	24 oc	32	1
	7/8	32 oc	48	2

(a) Low slope roofs are applicable to built-up, single-ply and modified bitumen roofing systems. For guaranteed or warranted roofs contact membrane manufacturer for acceptable deck. Low-slope roofs have a slope that is less than 2/12 (2°/foot).

(b) Edge support may also be provided by tongue-and-groove edges or solid blocking.

FIGURE 21

APA PANEL ROOF SHEATHING

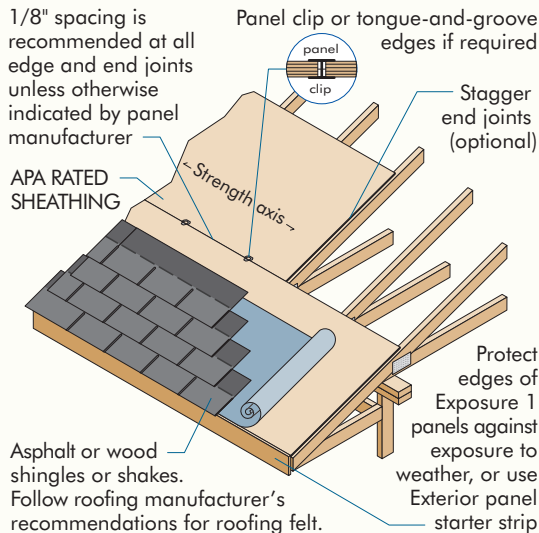

Notes:

1. Cover sheathing as soon as possible with roofing felt for extra protection against excessive moisture prior to roofing application.
2. For pitched roofs, place skid-resistant coating up if OSB panels are used. Keep roof surface free of dirt, sawdust and debris, and wear skid-resistant shoes when installing roof sheathing.
3. For buildings with conventionally framed roofs (trusses or rafters), limit the length of continuous sections of roof area to 80 feet maximum during construction, to allow for accumulated expansion in wet weather conditions. Omit roof sheathing panels in each course of sheathing between sections, and install "fill in" panels later to complete roof deck installation prior to applying roofing.

TABLE 32

RECOMMENDED MINIMUM FASTENING SCHEDULE FOR APA PANEL ROOF SHEATHING (Increased nail schedules may be required in high wind zones and where roof is engineered as a diaphragm.)

Panel Performance Category ^(c)	Size ^(d)	Nailing ^{(a)(b)}	
		Maximum Spacing (in.)	
		Supported Panel Edges ^(e)	Intermediate
3/8 – 1	8d	6	12 ^(f)
1-1/8	8d or 10d	6	12 ^(f)

- Use common smooth or deformed shank nails for panels with Performance Category 1 or smaller. For 1-1/8 Performance Category panels, use 8d ring- or screw-shank or 10d common smooth-shank nails.
- Other code-approved fasteners may be used.
- For stapling asphalt shingles to Performance Category 3/8 and thicker panels, use staples with a 15/16-inch minimum crown width and a 1-inch leg length. Space according to shingle manufacturer's recommendations.
- See Table 5, page 14, for nail dimensions.
- Supported panel joints shall occur approximately along the centerline of framing with a minimum bearing of 1/2". Fasteners shall be located 3/8 inch from panel edges.
- For spans 48 inches or greater, space nails 6 inches at all supports.

Notes: Gluing of roof sheathing to framing is not recommended, except when recommended by the adhesive manufacturer for roof sheathing that already has been permanently protected by roofing.

The Span Rating in the trademark applies when the long panel dimension or strength axis is across supports unless the strength axis is otherwise identified.

from Table 30, and minimum fastener requirements are given in Table 32. Increased nail schedules may be required in high wind zones. Recommended nail schedules for high wind zones are described in *APA Data File: Roof Sheathing Fastening Schedules for Wind Uplift, Form T325*.

APA RATED SHEATHING is equally effective under built-up roofing, asphalt or fiberglass shingles, tile roofing, or wood shingles or shakes. Roof trusses spaced 24 inches on center are widely recognized as the most economical construction for residential roofs. However, using fewer supports with thicker panels – e.g., Performance Category 23/32 or 3/4 panels with a span rating of 48/24 over framing 48 inches on center – is also cost effective for long-span flat or pitched roofs. Recommended live loads are given in Table 30. Nailing recommendations are given in Table 32.

When support spacing exceeds the maximum length of an unsupported edge (see Table 30), provide adequate blocking, tongue-and-groove edges, or other edge support such as panel clips. Some types of panel clips, in addition to edge support, automatically assure proper panel spacing. When required, use one panel clip per span, except use two clips for 48-inch or longer spans.

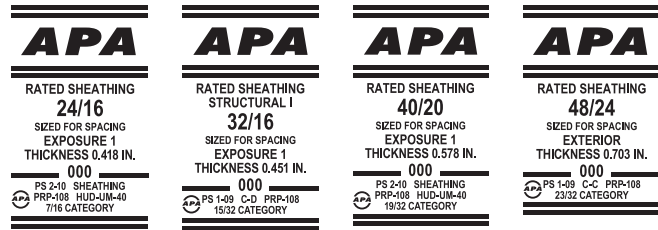

See APA's *Build A Better Home: Roofs, Form A535*, for additional recommended details to prevent moisture infiltration in roofs.

Preframed Roof Panels

Spans of 8 to 12 feet are usually the most practical with preframed panel construction, although spans to 30 feet are not uncommon. APA panels with stiffeners preframed at 16 or 24 inches on center (Figure 22) are common. The long dimension or strength axis of the panel typically runs parallel to supports. Stiffeners and roof purlins provide support for all panel edges. Minimum nailing requirements for preframed panels are the same as for roof sheathing.

In preframed panels 8x8 feet or larger (Figure 23), the panel strength axis may run either parallel or perpendicular to stiffeners spaced 16 or 24 inches on center. Stiffeners and roof purlins provide support for all panel edges. Recommendations in Table 33 are based on long dimension or strength axis of the panel parallel to supports. Deflection limits are 1/180 of the span for total load; 1/240 for live load only. See Table 34 for design information on stiffeners for preframed panels. Nailing requirements for preframed panels are the same as for roof sheathing.

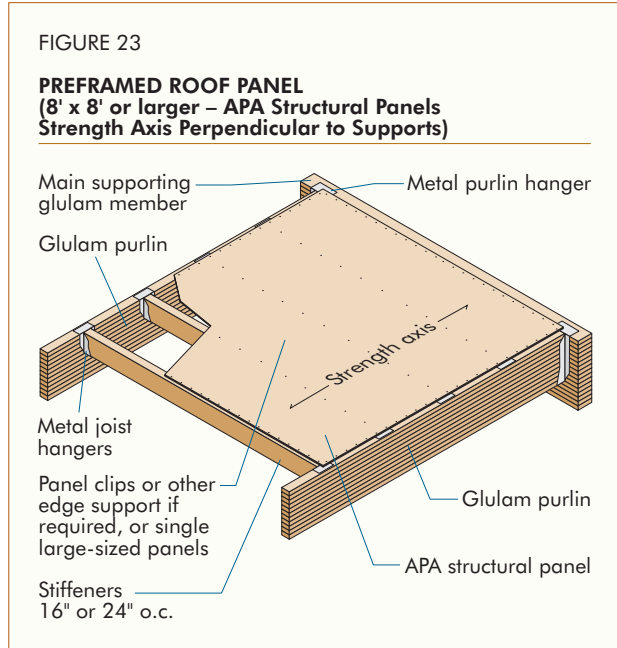
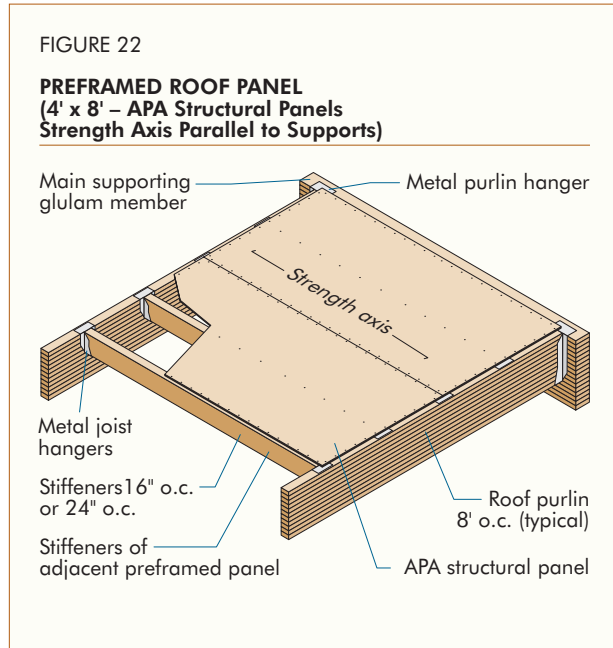

TABLE 33

RECOMMENDED ROOF LOADS (PSF) FOR APA RATED SHEATHING WITH STRENGTH AXIS PARALLEL TO SUPPORTS^{(a)(b)} (OSB and 5-ply/5-layer plywood panels unless otherwise noted)

Panel Grade	Panel Performance Category	Span Rating	Maximum Span (in.)	Load at Maximum Span	
				Live	Total
APA STRUCTURAL I RATED SHEATHING	7/16	24/16	24 ^(c)	15	25
	15/32, 1/2	32/16	24	30 ^(d)	40 ^(d)
	19/32, 5/8	40/20	24	70 ^(e)	80 ^(e)
	23/32, 3/4	48/24	24	105 ^(f)	115 ^(f)
APA RATED SHEATHING	7/16	24/16	16	35	45
	15/32, 1/2	32/16	24 ^(c)	15 ^(g)	25 ^(g)
	19/32, 5/8	40/20	24	40 ^(h)	50 ^(h)
	23/32, 3/4	48/24	24	70 ^(e)	80 ^(e)

- (a) For guaranteed or warranted roofs, contact membrane manufacturer for acceptable deck.
- (b) Provide edge support.
- (c) Solid blocking recommended at panel ends for 24-inch span.
- (d) For 4-ply plywood, reduce load by 10 psf.

- (e) For 4-ply plywood, reduce load by 30 psf.
- (f) For 4-ply plywood, reduce load by 45 psf.
- (g) For 4-ply plywood, reduce load by 5 psf.
- (h) For 4-ply plywood, reduce load by 15 psf.

TABLE 34

STIFFENER LOAD-SPAN TABLES FOR PREFRAMED APA PANEL ROOF DECKS

Douglas fir-Larch		Allowable Roof Live Load (psf) ^(a)											
Center-to-Center Purlin Spacing ^(b) (ft)	Stiffener Size and Spacing (in.)	Select Structural			No. 1 & Better			No. 1			No. 2		
		Strength ^(d)			Strength ^(d)			Strength ^(d)			Strength ^(d)		
		Defl. ^(c)	1.15	1.25	Defl. ^(c)	1.15	1.25	Defl. ^(c)	1.15	1.25	Defl. ^(c)	1.15	1.25
8	2x4@16	37	67	73	35	51	57	33	41	46	31	36	40
	2x4@24	25	41	46	23	31	34	22	24	27	21	21	23
	2x6@16	144	154	168	136	121	133	129	99	109	121	88	97
	2x6@24	96	99	109	91	78	85	86	63	69	81	56	61
	2x6@32	72	61	68	68	47	52	64	38	42	61	33	37
Southern Pine		Allowable Roof Live Load (psf) ^(a)											
Center-to-Center Purlin Spacing ^(b) (ft)	Stiffener Size and Spacing (in.)	Select Structural			No. 1 Dense			No. 1			No. 2		
		Strength ^(d)			Strength ^(d)			Strength ^(d)			Strength ^(d)		
		Defl. ^(c)	1.15	1.25	Defl. ^(c)	1.15	1.25	Defl. ^(c)	1.15	1.25	Defl. ^(c)	1.15	1.25
8	2x4@16	35	87	96	35	58	64	33	53	59	31	41	46
	2x4@24	23	55	60	23	35	39	22	32	36	21	24	27
	2x6@16	136	205	223	136	137	150	129	129	141	121	95	104
	2x6@24	91	133	146	91	88	97	86	83	91	81	60	66
	2x6@32	68	83	91	68	54	60	64	50	56	61	36	40

- (a) Final allowable load is the lesser of the loads as determined by deflection and stress.
- (b) Actual span of stiffeners taken as 3-1/2 inches less than center-to-center spacing of purlins.

- (c) Deflection limitations: Span/240 under live load only; Span/180 under total load, assuming a dead load of 10 psf.
- (d) Loads limited by stress are based on two conditions of duration of load: two months, such as for snow (1.15); and seven days (1.25); includes effects of 10 psf dead load.

Long Span Systems

Both preframed panel systems and direct application of sheathing to secondary or primary framing are common approaches in long span roof construction. Bay spacing and type of framing govern the choice.

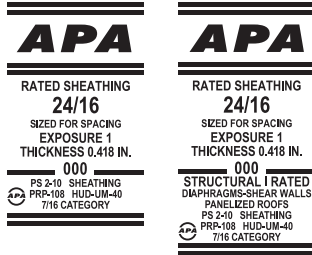

Experience shows that panels over supports 48 inches on center often yield maximum economy. Panels with a Span Rating of 48/24 are good for at least 35 psf snow load and meet the requirements for most guaranteed or warranted roofs. **Panels are assumed continuous over two spans with long dimension or strength axis across supports.**

FIGURE 24

TYPICAL CONNECTIONS TO ENGINEERED FLAT ROOF MEMBERS

Panels Nailed to Wood I-Joist

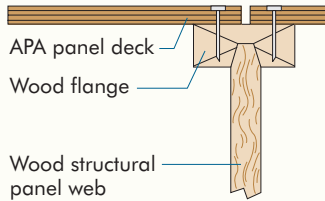

Panels Nailed to Open-Web Parallel-Chord Wood Truss

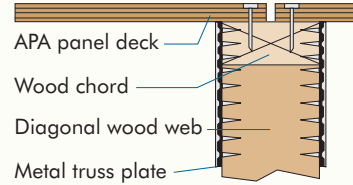

Panels Nailed to Nailer Bolted to Steel Joist

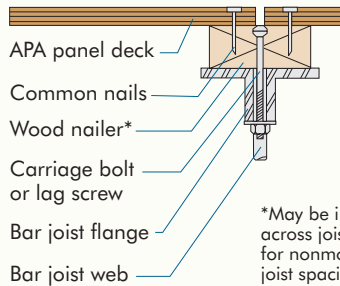

*May be installed across joists (good for nonmodular joist spacing).

Panels Nailed to Glulam Beam

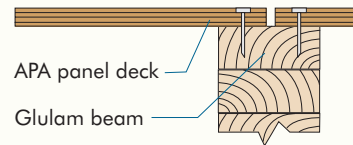

Figure 24 illustrates typical connections for engineered flat roof members.

Plywood Under Special Coatings

Chemical coatings for roofs have increased the range of design possibilities, particularly in larger commercial structures with contoured or steeply pitched roof surfaces exposed to view.

The plywood thickness and span recommendations in Table 35 for plywood under special coatings assume installation with the **panel continuous over two or more spans with the long dimension or strength axis perpendicular to supports** and liquid coatings applied directly to the plywood. Check local building codes for any required deviations from these recommendations. Allowable roof live load is based on the same deflection criteria as described in Table 30 for APA panel roof sheathing.

TABLE 35

PLYWOOD THICKNESS AND MAXIMUM SPANS FOR ROOF DECKS UNDER SPECIAL COATINGS^(a)

Grade	Minimum Plywood Performance Category	Maximum Support Spacing (in.)			Nail Type & Size ^{(b)(c)}	Maximum Nail Spacing (in.)	
		Group 1	Groups 2 & 3	Group 4		Supported Panel Edges	Intermediate Supports
	11/32	16	—	—	8d common smooth ^(d) or ring- or screw-shank	6	12
APA A-C EXT APA B-C EXT	15/32, 1/2	24	24	16	8d common smooth ^(d) or ring- or screw-shank	6	12
APA C-C PLUGGED EXT	19/32, 5/8	32	24	24	8d ring- or screw-shank	6	12
	23/32, 3/4	40	32	32	8d ring- or screw-shank	6	12
	7/8	48	40	40	8d ring- or screw-shank	6	12 ^(e)

(a) All panels will support at least 30 psf live load plus 10 psf dead load at maximum span.

(b) Nail type, size and spacing may vary for engineered diaphragm designs.

(c) See Table 5, page 14, for nail dimensions.

(d) Use only deformed-shank nails for curved surfaces.

(e) For spans 48 inches or greater, space nails maximum 6 inches at all supports.

Exterior plywood is recommended for use under special coatings for roofs. Where the coating requires a very smooth base, use APA A-C Exterior or APA B-C Exterior plywood. Where maximum smoothness is not essential, use APA C-C PLUGGED Exterior. Tongue-and-groove plywood (Performance Category 15/32 or larger) or lumber blocking at panel edges is recommended. A 1/8-inch space is recommended at all edge and end joints unless otherwise indicated by panel manufacturer. If high-performance coatings are to be used for finish, check coating manufacturer's recommendations for panel joint treatment. Nail size, type and spacing recommendations are also given in Table 35.

Grades recommended in Table 35 should also be specified for the top layer when the structural wood deck is to be overlaid with a separate plywood layer to serve as substrate for special roof coatings. A 1/8-inch space is recommended at all edge and end joints unless otherwise indicated by panel manufacturer. Although minimum 1/4-inch plywood may be used over structural decks, Performance Category 15/32 or larger panels should be considered for best performance over uneven surfaces or when rain or high humidity is anticipated prior to application of roof coating. Use corrosion-resistant fasteners sized and spaced as recommended in Table 35.

APA Panel Soffits

Recommended spans for open and closed APA panel soffits are given in Tables 36 and 37. The recommendations in Table 36 for open soffits also apply to combined roof/ceiling construction. **Panels are assumed continuous over two or more spans with the long dimension or strength axis across supports** for both applications. For appearance purposes in open soffit construction, provide blocking, tongue-and-groove edges, or other suitable edge support. Panels will support at least 30 psf live load, plus 10 psf dead load.

For open soffit and nonstructural ceiling construction, panels designated Exposure 1 are recommended as a minimum (check local building code) where appearance is not a major consideration.

TABLE 36

APA PANELS FOR OPEN SOFFIT OR FOR COMBINED ROOF DECKING-CEILING^{(a),(b)}
(Strength axis across supports. For APA RATED SHEATHING, where appearance is not a major concern, see Table 30.)

Maximum Span (inches)	Panel Description (All panels Exterior or Exposure 1)	Species Group for Plywood
16	Performance Category 15/32 APA RATED SIDING 303	1, 2, 3, 4
	Performance Category 15/32 APA MDO, Sanded and Touch-Sanded Plywood	1, 2, 3, 4
24	Performance Category 15/32 APA RATED SIDING 303	1
	Performance Category 15/32 APA MDO, Sanded and Touch-Sanded Plywood	1, 2, 3
	Performance Category 19/32 APA RATED SIDING 303	1, 2, 3, 4
	Performance Category 19/32 APA MDO, Sanded and Touch-Sanded Plywood	1, 2, 3, 4
	APA RATED STURD-I-FLOOR 16 oc	—
32	Performance Category 19/32 APA RATED SIDING 303	1
	Performance Category 19/32 APA MDO, Sanded and Touch-Sanded Plywood	1
	Performance Category 23/32 APA Textured Plywood ^(c)	1, 2, 3, 4
	Performance Category 23/32 APA MDO, Sanded and Touch-Sanded Plywood	1, 2, 3, 4
	APA RATED STURD-I-FLOOR 20 oc	—
48	Performance Category 1-1/8 APA Textured Plywood ^(c)	1, 2, 3, 4
	APA RATED STURD-I-FLOOR 48 oc	—

(a) All panels will support at least 30 psf live load plus 10 psf dead load at maximum span.

(b) For appearance purposes, blocking, tongue-and-groove edges or other suitable edge supports should be provided.

(c) Also see Table 30 for APA RATED SHEATHING/CEILING DECK.

TABLE 37

APA PANELS FOR CLOSED SOFFIT OR FOR NONSTRUCTURAL CEILING^{(a),(b)} (Strength axis across supports)

Maximum Span (in.) All Edges Supported	Panel Performance Category	Species Group	Nail Size and Type ^(c)
24	11/32 APA ^(d)	All Species Groups	6d nonstaining box or casing
32	15/32 APA ^(d)		8d nonstaining box or casing
48	19/32 APA ^(d)		8d nonstaining box or casing

(a) Space nails maximum 6 inches at panel edges and 12 inches at intermediate supports for spans less than 48 inches; 6 inches at all supports for 48-inch spans.

(b) For appearance purposes, blocking, tongue-and-groove edges or other suitable edge supports should be provided.

(c) See Table 5, page 14, for nail dimensions.

(d) Any suitable grade panel which meets appearance requirements – Exterior for closed soffits, Exposure 1 or Exterior for nonstructural ceiling.

Only Exterior panels should be used for closed soffits.

At eaves where Exposure 1 sheathing is used for roof decking, protect panel edges against direct exposure to the weather with fascia trim.

Although unsanded and touch-sanded grades of plywood are often used for applications such as soffits, optimum appearance and finish performance is attained by using panels with textured or sanded A-grade faces. For panel grades other than APA RATED SIDING 303, top-quality acrylic latex house paint systems provide best performance (see page 55). Face-checking (separations between fibers parallel to the grain of the face veneer) can be expected on non-overlaid plywood which is exposed to the outdoors, even when finished. If a smooth, check-free surface is desired, use Medium Density Overlay (MDO) plywood.

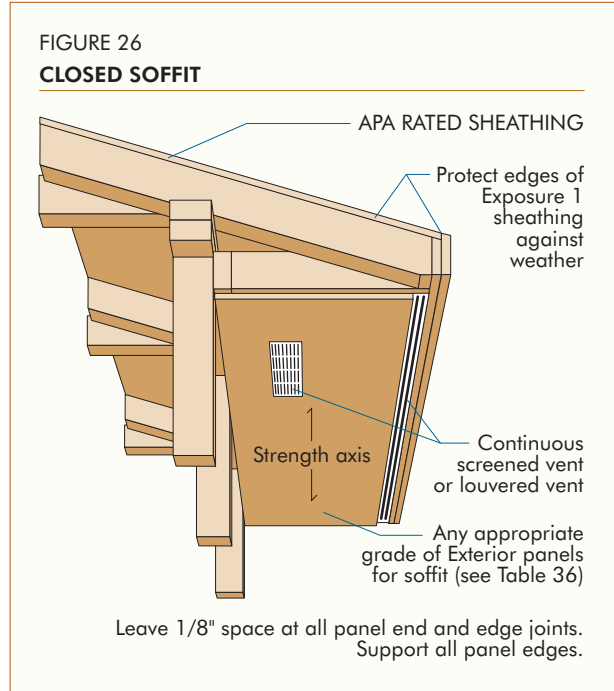
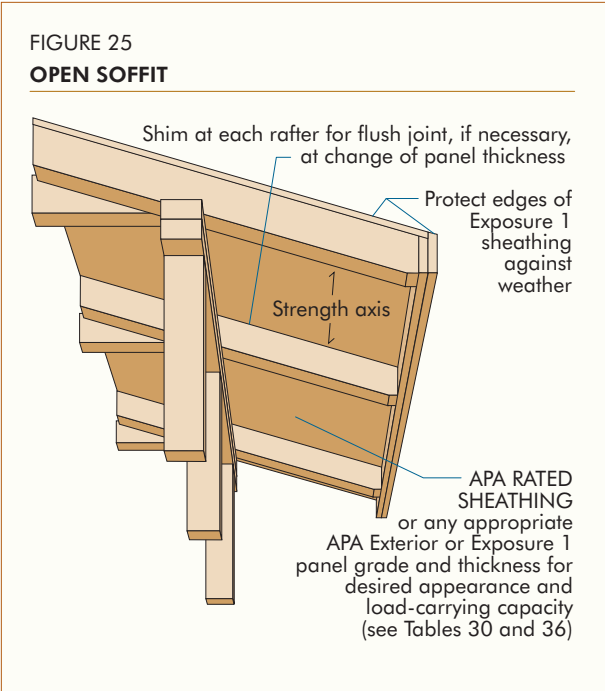

APA Panel Roof Diaphragms

With only slight design modifications, any APA panel roof deck system described in the previous sections will also function as an engineered diaphragm to resist high wind and seismic loading. A diaphragm’s ability to function effectively as a beam, transferring lateral loads to shear walls, is related to the quality of the connections. Nailing is critical since shear loads are transmitted through these fasteners. Common nails provide required strength. Other nail types may be used when their lateral bearing values are considered in the design. Load-carrying capacity is highest when the diaphragm is blocked.

Where Performance Category 1-1/8 roof panels are desired, such as for Heavy Timber construction (see page 75), shear values for Performance Category 19/32 panels are used. Blocked shear values for Performance Category 1-1/8 panels may be obtained by specifying stapled tongue-and-groove edges. Staples shall be 16 gauge, 1 inch long with a 3/8-inch crown, driven through the tongue-and-groove edges 3/8 inch from the joint so as to penetrate the tongue with both legs of the staple. Staples shall be spaced at one-half of the diaphragm boundary nail spacing for Cases 1 and 2, and at one-third the diaphragm boundary nail spacing for Case 3 through 6, as illustrated in Table 38.

Table 38 gives panel and fastening recommendations for roof diaphragms. Panels and framing are assumed already designed for perpendicular loads. To design a diaphragm, follow these steps:

1. Determine lateral loads and resulting shears.
2. Determine nailing schedule (Table 38). Consider load direction with respect to joints.
3. Compute chord stress due to bending moment. Provide adequate splices. Check deflection. Check anchorage of boundary framing (e.g., chords) to walls.

For information about developing higher diaphragm shears than shown in Table 38, see *APA Design/Construction Guide: Diaphragms and Shear Walls*, Form L350.

 RATED SHEATHING 24/0 SIZED FOR SPACING EXPOSURE 1 THICKNESS 0.354 IN. 000 STRUCTURAL I RATED DIAPHRAGMS-SHEAR WALLS PS 2-10 HUD-JUM-40 PRP-108 HUD-UM-40 3/8 CATEGORY	 RATED SHEATHING 24/16 SIZED FOR SPACING EXPOSURE 1 THICKNESS 0.418 IN. 000 PS 2-10 SHEATHING PRP-108 HUD-JUM-40 7/8 CATEGORY	 RATED SHEATHING STRUCTURAL I 32/16 SIZED FOR SPACING EXPOSURE 1 THICKNESS 0.451 IN. 000 PS 1-09 C-D PRP-108 15/32 CATEGORY	 RATED SHEATHING 40/20 SIZED FOR SPACING EXPOSURE 1 THICKNESS 0.578 IN. 000 PRP-108 HUD-JUM-40 19/32 CATEGORY
---	--	---	---

TABLE 38

ALLOWABLE SHEAR (POUNDS PER FOOT) FOR HORIZONTAL APA PANEL DIAPHRAGMS WITH FRAMING OF DOUGLAS-FIR, LARCH OR SOUTHERN PINE^(a) FOR WIND^{(b)(c)} OR SEISMIC LOADING^(c)

Panel Grade	Common Nail Size ^(f)	Minimum Nail Penetration in Framing (in.)	Minimum Nominal Panel Thickness (in.)	Minimum Nominal Width of Framing Members at Adjoining Panel Edges and Boundaries ^(g) (in.)	Blocked Diaphragms				Unblocked Diaphragms			
					Nail Spacing (in.) at diaphragm boundaries (all cases), at continuous panel edges parallel to load (Cases 3 & 4), and at all panel edges (Cases 5 & 6) ^(d)				Nails Spaced 6" max. at Supported Edges ^(d)			
					Nail Spacing (in.) at other panel edges (Cases 1, 2, 3 & 4) ^(d)				Case 1 (No unblocked edges or continuous joints parallel to load)		All other configurations (Cases 2, 3, 4, 5 & 6)	
					6	4	2-1/2 ^(e)	2 ^(e)	6	6	4	3
APA STRUCTURAL I grades	6d ^(h)	1-1/4	5/16	2	185	250	375	420	165	125		
				3	210	280	420	475	185	140		
	8d	1-3/8	3/8	2	270	360	530	600	240	180		
				3	300	400	600	675	265	200		
10d ⁽ⁱ⁾	1-1/2	15/32	2	320	425	640	730	285	215			
			3	360	480	720	820	320	240			
APA RATED SHEATHING APA RATED STURD-I-FLOOR and other APA grades except Species Group 5	6d ^(h)	1-1/4	5/16	2	170	225	335	380	150	110		
			3	190	250	380	430	170	125			
	8d	1-3/8	7/16	2	255	340	505	575	230	170		
				3	285	380	570	645	255	190		
	10d ⁽ⁱ⁾	1-1/2	15/32	2	270	360	530	600	240	180		
				3	300	400	600	675	265	200		
	10d ⁽ⁱ⁾	1-1/2	19/32	2	290	385	575	655	255	190		
				3	325	430	650	735	290	215		
				2	320	425	640	730	285	215		
				3	360	480	720	820	320	240		

- (a) For framing of other species: (1) Find specific gravity for species of lumber in the AF&PA National Design Specification (NDS). (2) Find shear value from table above for nail size for actual grade. (3) Multiply value by the following adjustment factor: Specific Gravity Adjustment Factor = [1 - (0.5 - SG)], where SG = specific gravity of the framing. This adjustment shall not be greater than 1.
- (b) For wind load applications, the values in the table above shall be permitted to be multiplied by 1.4.
- (c) For shear loads of normal or permanent load duration as defined by the AF&PA NDS, the values in the table above shall be multiplied by 0.63 or 0.56, respectively.
- (d) Space nails maximum 12 inches o.c. along intermediate framing members (6 inches o.c. when supports are spaced 48 inches o.c. or greater). Fasteners shall be located 3/8" from panel edges.

- (e) Framing at adjoining panel edges shall be 3" nominal or wider, and nails shall be staggered where nails are spaced 2 inches o.c. or 2-1/2 inches o.c.
- (f) See Table 5, page 14, for nail dimensions.
- (g) The minimum normal width of framing members not located at boundaries or adjoining panel edges shall be 2".
- (h) 8d is recommended minimum for roofs due to negative pressures of high winds.
- (i) Framing at adjoining panel edges shall be 3" nominal or wider, and nails shall be staggered where 10d nails having penetration into framing of more than 1-1/2" are spaced 3 inches o.c.

Note: Design for diaphragm stresses depends on direction of continuous panel joints with reference to load, not on direction of long dimension or strength axis of sheet. Continuous framing may be in either direction for blocked diaphragms.

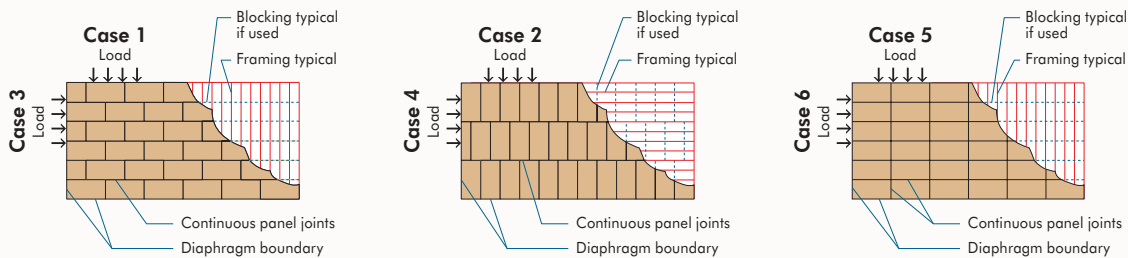



BUILDING REQUIREMENTS AND RELATED PANEL SYSTEMS

Fire-resistant Construction

Protected Construction

Protected construction includes typical floor-ceiling, roof-ceiling or wall assemblies with wood structural panels fastened to wood or steel framing, and a fire-resistive material, such as gypsum wallboard, plaster or mineral acoustical tile, added to give primary protection to framing. The structural panels slow flame passage and temperature rise while reinforcing supports against collapse under load.

Assemblies are rated in fire tests by Underwriters Laboratories (U.L.) and other agencies. Over 40 floor-ceiling (and/or roof-ceiling) systems using wood structural panels are described in the *U.L. Fire Resistance Directory*. They are accepted as rated constructions by most building codes. Examples of one-hour-rated floor-ceiling assemblies are shown in [Figures 27 and 28](#); several two-hour-rated wood-framed assemblies also are described in the U.L. Directory. For additional information, see *APA Design/Construction Guide: Fire-Rated Systems, Form W305*.

Starting with the 2009 IBC and IRC, one- and two-family dwellings are required to be sprinklered (IBC 903.2.8 and IRC R313.1). However, not all local jurisdictions in the U.S. have adopted these provisions for the use of sprinkler systems as an active home fire protection system. Then in May 2010, the International Code Council (ICC) approved the following new fire protective membrane provisions to the 2012 IRC:

R501.3 Fire protection of floors. *Floor assemblies, not required elsewhere in this code to be fire resistance rated, shall be provided with a 1/2 inch gypsum wallboard membrane, 5/8 inch wood structural panel membrane, or equivalent on the underside of the floor framing member.*

Exceptions:

1. Floor assemblies located directly **over** a space protected by an automatic sprinkler system in accordance with Section P2904, NFPA13D, or other approved equivalent sprinkler system.
2. Floor assemblies located directly over a crawl space not intended for storage or fuel-fired appliances.
3. Portions of floor assemblies can be unprotected when complying with the following:
 - 3.1 The aggregate area of the unprotected portions shall not exceed 80 square feet per story.
 - 3.2 Fire blocking in accordance with Section R302.11.1 shall be installed along the perimeter of the unprotected portion to separate the unprotected portion from the remainder of the floor assembly.
4. Wood floor assemblies using dimension lumber or structural composite lumber equal to or greater than 2-inch by 10-inch nominal dimension, or other approved floor assemblies demonstrating equivalent fire performance.

It should be noted that these fire protective membrane provisions apply to not only I-joist floors but all residential floor assemblies, including floor trusses, light-gauge steel framing, and dimension lumber and structural composite lumber less than 2-inch by 10-inch nominal dimension. They will become effective when adopted by the local jurisdiction. While most jurisdictions will consider the adoption of the 2012 IRC after it is published in late 2011, some local jurisdictions may elect to adopt them sooner, and others may not adopt them at all.

Based on this, APA supports the addition of a 1/2-inch gypsum wall board or 5/8-inch wood structural panel fire protective membrane, or equivalent, to the underside of floor framing, as required by Section R501.3 of the 2012 IRC. The designer and builder shall consult with the local building department or authority having jurisdiction for specific requirements of fire protection in any building construction.

FIGURE 27

ONE-HOUR COMBUSTIBLE FLOOR-CEILING AND ROOF-CEILING ASSEMBLIES – LUMBER JOISTS

Some rated assemblies incorporate proprietary products. When designing and specifying, check the Underwriters Laboratories Inc. (U.L.) Fire Resistance Directory for complete details on a particular assembly. A change in details may affect the fire resistance of the assembly.

27.A TWO-LAYER FLOOR SYSTEM WITH LUMBER JOISTS^{(a)(b)}

For details, see U.L. Design Nos. L004, L005, L006, L201, L202, L206, L209, L210, L211 (2 hr), L212, L501, L502, L503, L505 (2 hr), L507, L511 (2 hr), L512, L513, L514, L515, L516, L519, L522, L523, L525, L526, L532 (1-1/2 hr), L533, L535, L536 (2 hr), L537, L539, L540, L541 (2 hr), L545, and L569. Also see U.L. Design Nos. L524 with steel joists spaced 24" o.c., L521, L528, L529, and L534 with wood trusses spaced 24" o.c., L549 with steel trusses spaced 48" o.c., and L527 with steel joists spaced 24" o.c.

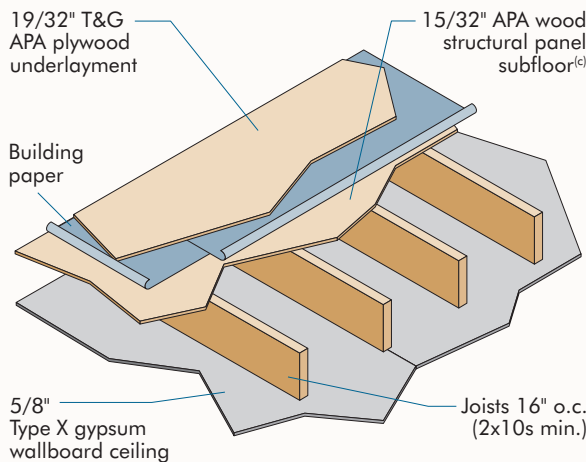

27.B SINGLE-LAYER FLOOR SYSTEM WITH LUMBER JOISTS

For details, see U.L. Design No. L513. Also see U.L. Design Nos. L504 for stressed-skin panel (5/8" APA RATED STURD-I-FLOOR or SHEATHING plywood with joists spaced 12" o.c.), L507 for 5/8" APA RATED STURD-I-FLOOR plywood with joists spaced 16" o.c., L508 for 1-1/8" APA RATED STURD-I-FLOOR plywood with joists spaced 48" o.c., and L539, L540 with joists spaced 16" or 24" o.c. and separate ceiling assembly (for modular housing units). Also see U.L. Design Nos. L524 and L543 with steel joists spaced 19.2" or 24" o.c. (L543 with separate ceiling assembly).

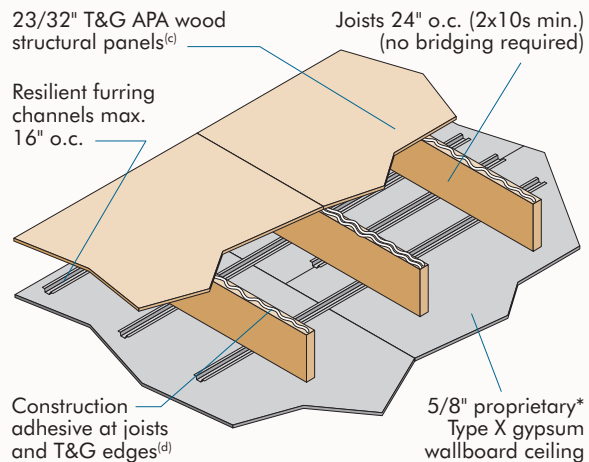

(a) Substitution of 1-1/8" APA RATED STURD-I-FLOOR 48 oc for the combination of subfloor, paper and underlayment is often allowed. Check with local building official.

(b) Most building codes do not require the top layer of two-layer rated assemblies when used for roofs.

(c) Tests have shown that substitution of OSB or composite APA RATED SHEATHING subfloor and APA RATED STURD-I-FLOOR

*For proprietary names, see latest U.L. Fire Resistance Directory.

underlayment for the plywood panels in rated assemblies will not jeopardize fire-resistance ratings. Substitution is based on equivalent panel thickness, except that in two-layer wood assemblies 7/16" OSB subfloor panels may be used in place of 15/32" plywood subfloor panels.

(d) Construction adhesive to conform to APA Specification AFG-01 (ASTM D3498).

FIGURE 28

ONE-HOUR COMBUSTIBLE FLOOR-CEILING AND ROOF-CEILING ASSEMBLIES – I-JOISTS

28.A – ONE-HOUR FIRE-RESISTIVE/CEILING ASSEMBLY

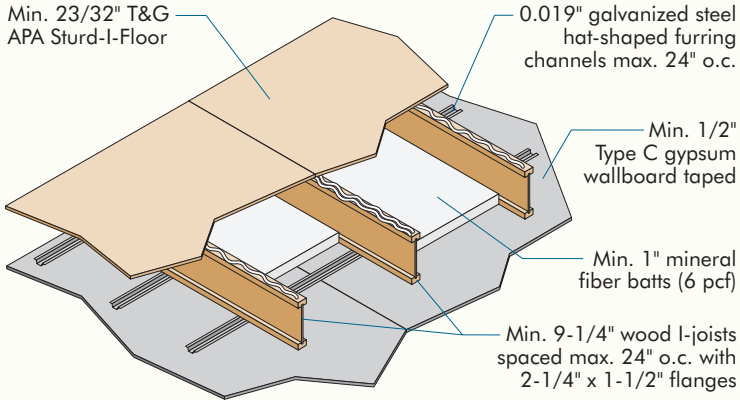

For additional details, see *AF&PA DCA 3, Assembly WIJ-1.4* (www.afandpa.org)

STC AND IIC SOUND RATINGS

Without Gypsum Concrete			
Cushioned Vinyl		Carpet and Pad	
STC	IIC	STC	IIC
–	–	46	68
With Gypsum Concrete			
Cushioned Vinyl		Carpet and Pad	
STC	IIC	STC	IIC
51	47	50	73

28.B – ONE-HOUR FIRE-RESISTIVE FLOOR/CEILING ASSEMBLY^(a)

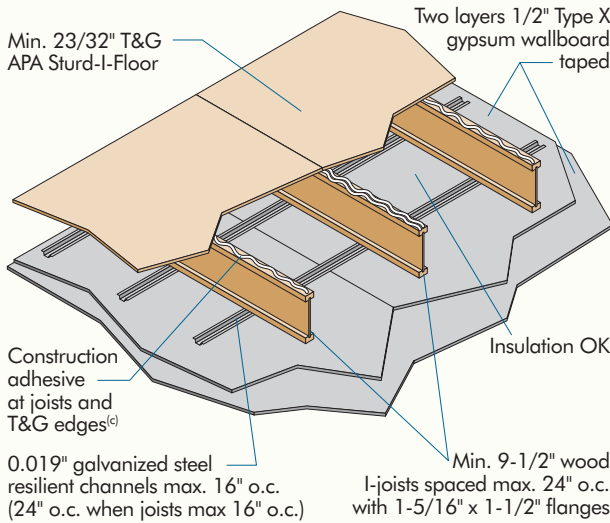

For additional details, see *AF&PA DCA 3, Assembly WIJ-1.6* (www.afandpa.org)

STC AND IIC SOUND RATINGS

	Without Gypsum Concrete			
	Cushioned Vinyl		Carpet and Pad	
	STC	IIC	STC	IIC
With Insulation	59	50	55 ^(b)	68 ^(b)
Without Insulation	–	–	54	68
With Gypsum Concrete				
	Cushioned Vinyl		Carpet and Pad	
	STC	IIC	STC	IIC
With Insulation	60	51	63 ^(b)	65 ^(b)
Without Insulation	–	–	58 ^(b)	55 ^(b)

For other plywood floor-ceiling assemblies, see U.L. Design Nos. L506 (3/4 hr), L509 (1/2 hr), L520 (3/4 hr).

The following fire-rated floor-ceiling or roof-ceiling assemblies include thermal or acoustical insulation in the joist cavity:

U.L. Design No.	Insulation	Thickness (in.)	U.L. Design No.	Insulation	Thickness (in.)
L211 (2 hr)	Glass fiber batts	6	L539	Glass fiber batts	3-5/8
L212	Glass fiber batts	6	L540	Glass fiber batts	3-5/8
L507	Mineral wool (blown in)	9-1/4	L541 (2 hr)	Mineral wool batts	3
L516	Glass fiber batts	3	L543	Mineral wool (blown in)	3-1/2
L520 (3/4 hr)	Glass fiber batts	3	L545	Glass fiber batts	3
L521	Glass fiber batts	3-1/2	L549	Glass fiber or mineral wool batts	Any
L532 (1-1/2 hr)	Glass fiber batts	3-1/2	L569	Glass fiber or mineral wool batts	3-1/2
L533	Glass fiber batts	3			

(a) This assembly may also be used in a fire-rated roof/ceiling application, but only when constructed exactly as described.

(b) STC and IIC values estimated by David L. Adams Associates, Inc.

(c) Construction adhesive to conform to ASTM D3498 or APA Specification AFG-01.

Building Requirements

In many fire-resistant floor-ceiling assemblies, a two-layer floor system (Performance Category 15/32 subfloor and Performance Category 19/32 underlayment) is used, although several have single-layer Performance Category 5/8 or larger combination subfloor-underlayment panels. Any finish floor material may be used. The International Building Code permits omission of the top panel layer in roof assemblies or where unusable space occurs above (Table 720.1(3)).

Plywood siding or wall sheathing in combination with gypsum sheathing and wallboard on studs is recognized by code officials for one-hour load-bearing exterior walls. A typical example – APA RATED SIDING over 5/8-inch Type X gypsum sheathing attached to 2x studs 16 or 24 inches on center – is illustrated in Figure 29. Under the International Building Code, Section 705.5, the fire-resistive rating for exterior walls applies only to the inside of the wall when separation to the property line is greater than 10 feet. In this common situation, the gypsum sheathing can be omitted under the siding as noted in Figure 29.

Fire-rated protected wall assemblies will qualify for the one-hour rating if other materials are added over the fire-resistive materials. For example, APA RATED SIDING panels or lap siding may be attached to the outside of a rated wall without impairing the rating. APA RATED SHEATHING is also permitted between the fire protection and wood studs (Table 720.1(2) of the 2009 IBC). For additional information, see *APA Design/Construction Guide: Fire-Rated Systems, Form W305* and *APA Technical Topic: Load-Bearing Fire-Rated Wall Assemblies with OSB and Plywood Wall Sheathing, Form TT-063*.

FIGURE 29

ONE-HOUR FIRE-RATED EXTERIOR LOAD-BEARING WALL ASSEMBLY^(a)

2x4 studs all 16" or 24" o.c.

Mineral or glass fiber insulation (optional)

5/8" Type X gypsum wallboard

5/8" Type X gypsum sheathing^(b)

Building paper or other code-approved weather-resistive barrier

(a) Generic, non-proprietary assembly based on GA File No. WP8105 listed in *Gypsum Association Fire Resistance Design Manual*, referenced in the model building codes. Mineral or glass fiber batt insulation (optional).

(b) Exterior layer of gypsum sheathing not required under the International Building Code, when separation is greater than ten feet. Check local provisions. Also see U.L. Design Nos. U344 and U356 in U.L. *Fire Resistance Directory*.

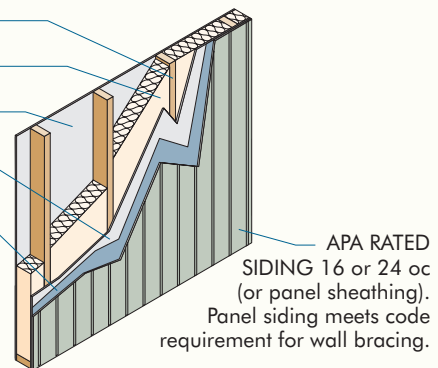

Sprinkler System Installation for APA Performance Rated I-Joists

APA Performance Rated wood I-joists (PRIs) are often used in conjunction with fire suppression sprinkler systems. Most wood I-joist design tables are based on an assumed uniform load. Joists and other supporting systems must be designed to carry the added weight of the sprinkler system. This may necessitate the use of deeper I-joists, joists with shorter spans, closer spacing and/or a different I-joist series with higher moment and stiffness capacities.

Refer to *APA Technical Note: Sprinkler System Installation for APA Performance Rated I-Joists, Form J745*, for detailed sprinkler system design and installation information.

For additional information on installing and designing with I-joists, including information on allowable spans, installation details, architectural specifications and engineering design properties, refer to *APA Performance Rated I-Joists, Form Z725* and *I-Joist Construction Details – Performance Rated I-Joists in Floor and Roof Framing, Form D710*.

Roof Coverings

The fire resistance ratings of roofing materials are listed as Class A, B, or C in descending order of fire protection afforded. Their use is prescribed by building codes, and also affects insurance rates. Untreated APA RATED SHEATHING panels are recognized as a structural roof deck substrate for rated roof coverings. For individual requirements, see the *U.L. Roofing Materials and Systems Directory*.

Wall and Ceiling Paneling

The Flame Spread Classification of materials used for interior wall and ceiling finish (and occasionally for other applications) is usually limited by building codes for certain occupancies. Tests have shown that untreated APA wood structural panels will develop flame spread index and smoke index values of 200 or less, which puts them in a Class C (or III) category.

Panels are therefore suitable as interior finish for most applications. Certain more restrictive locations, such as exitways, require a Class A or Class B rating, which can be achieved by the use of fire-retardant-treated plywood. (See page 17.)

Structural Glued Laminated Timber (Glulam)

A structural member's fire resistance is measured by the time it can support its design load during a fire. An exposed beam or column sized for a minimum one-hour fire resistance will support its full design load for at least one hour during standard ASTM E 119 fire test conditions which simulate an actual fire.

Beams. Glulam beams 6-3/4 and 8-3/4 inches wide can be adapted to a one-hour fire rating in accordance with procedures recognized by the ICC. For these widths, there is a minimum depth for a one-hour fire rating. The minimum depth increases when the design calls for the beam to be exposed on four rather than three sides (see Table 39).

To adapt beams whose dimensions qualify them for one-hour fire rating, the basic layup is modified as shown in Figure 30. One core lamination from the interior of the beam is replaced by an additional tension lamination.

Columns. Column length determines the minimum size for one-hour ratings. The column size needed for a one-hour fire rating is determined by calculating the ℓ/d and then using the appropriate minimum dimensions (see Table 40).

Columns generally need no special layup to qualify for a one-hour fire rating. For both 8-3/4- and 10-3/4-inch widths, all columns meeting the minimum size standard satisfy the one-hour fire rating requirement.

As with all structural framing, final specifications of members designed to have one-hour fire resistance should be carefully checked by a professional engineer or architect to assure compliance with all local building codes.

The use of pressure impregnated fire retardants is not recommended for glulam.

Metal Connectors. In structures using one-hour rated glulams, supporting metal connectors and fasteners also must be designed to achieve a one-hour fire rating. Fire-rated (Type X) gypsum wallboard, a 1-1/2-inch covering of wood or any coating approved for a one-hour rating provides the needed protection.

For further information, see *APA Technical Note: Calculating Fire Resistance of Glulam Beams and Columns, Form Y245*.

TABLE 39

ONE-HOUR FIRE-RATED GLULAM BEAMS – MINIMUM DEPTHS FOR 6-3/4" AND 8-3/4" WIDE BEAMS

Beam Width (in.)	Minimum Depth (in.)	
	3 Sides Exposed	4 Sides Exposed
6-3/4	13-1/2	27
8-3/4	7-1/2	13-1/2

TABLE 40

ONE-HOUR FIRE-RATED GLULAM COLUMNS – MINIMUM DEPTHS FOR 8-3/4" AND 10-3/4" COLUMN WIDTHS

ℓ/d Criteria	Column Width (in.)	Minimum Depth (in.)	
		3 Sides Exposed	4 Sides Exposed
$\ell/d > 11$	8-3/4	15	30
	10-3/4	10-1/2	13-1/2
$\ell/d \leq 11$	8-3/4	9	12
	10-3/4	7-1/2	10-1/2

ℓ = column length in inches.

d = column least cross-sectional dimension in inches.

FIGURE 30

ONE-HOUR FIRE-RATED GLULAM BEAM (Layup for simple span)

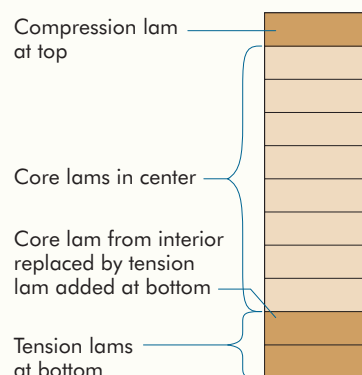

Heavy Timber Construction

Model building codes also recognize Heavy Timber wood construction systems, which can simplify roof or floor construction while providing superior fire resistance. Heavy Timber construction does not constitute one-hour fire resistance, however.

Under fire conditions, large size timber members develop a surface char layer, which acts as insulation to slow the burning process. In addition, Heavy Timber construction does not permit concealed wall or ceiling spaces where fire can spread. Years of fire service experience shows that the structural performance of Heavy Timber construction systems under fire conditions is markedly superior to most unprotected “noncombustible” (steel) structures.

See Table 41 for minimum structural member sizes required by model building codes for Heavy Timber construction. Structural glued laminated timber (glulam) also qualifies for Heavy Timber construction systems when members conform to required sizes.

Insurance rating bureaus and all of the model building codes accept Performance Category 1-1/8 tongue-and-groove wood structural panels (Exposure 1) as an alternative to 2-inch nominal tongue-and-groove lumber decking in Heavy Timber roof construction.

Typical construction (Figure 31) consists of tongue-and-groove APA RATED STURD-I-FLOOR 48 oc Exposure 1 (or Performance Category 1-1/8 tongue-and-groove APA RATED SHEATHING Exposure 1 – Check local availability before specifying). Heavy Timber beams must be 4x6 minimum and are normally spaced 48 inches on center. For an exposed ceiling with improved appearance, Performance Category 1-1/8 textured siding^(a) or APA RATED SHEATHING/CEILING DECK panels can be specified.

Heavy Timber floors may also be constructed with Performance Category 15/32 wood structural panels over 3-inch planks.

For additional information on fire-resistant construction, see *APA Design/Construction Guide: Fire-Rated Systems, Form W305*.

TABLE 41

DIMENSIONS OF COMPONENTS FOR HEAVY TIMBER CONSTRUCTION (TYPICAL CODE PROVISIONS)

Heavy Timber construction is generally defined in building codes and standards by the following minimum sizes for the various members or portions of a building:

	Inches, nominal
Columns – supporting floor loads	8 x 8
Supporting roof and ceiling loads only	6 x 8
Floor framing	
Beams and girders	6 wide x 10 deep
Arches and trusses	8 in any dimension
Roof framing – not supporting floor loads	
Arches springing from grade	6 x 8 lower half 6 x 6 upper half
Arches, trusses, other framing springing from top of walls, etc.	4 x 6
Floor (covered with 1-inch nominal flooring, Performance Category 15/32 or 1/2 wood structural panels, or other approved surfacing)	
Splined or tongue-and-groove plank	3
Planks set on edge	4
Roof decks	
Splined or tongue-and-groove plank	2
Plank set on edge.....	3
Tongue-and-groove wood structural panels	Performance Category 1-1/8

FIGURE 31

HEAVY TIMBER CONSTRUCTION

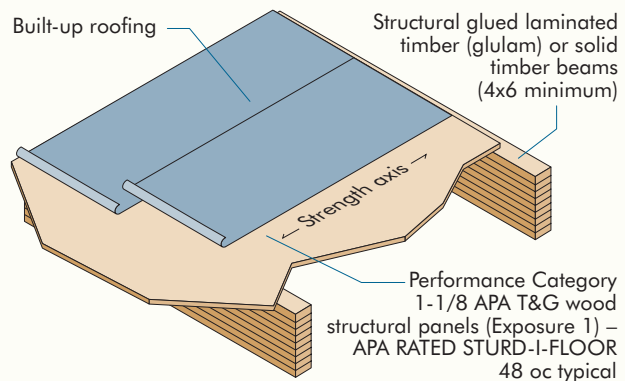

(a) Depending on siding thickness and support spacing, an additional layer of APA Rated Sheathing may be necessary.

Wind-resistive Roofs

Wind ratings are based on a roof system's performance in wind uplift tests. Systems meeting the requirements of these tests are assigned ratings that indicate how much pressure, in pounds per square foot, they successfully resisted in the test. Four Factory Mutual (FM) wind-rated assemblies are illustrated below.

Other roof systems with proprietary metal roofing panels, using plywood or OSB panels as a roofing substrate over steel decking, or as structural roof sheathing, also meet U.L. Class 90 requirements. See [Figure 36](#). For additional information see *APA Design/Construction Guide: Wind-Rated Roofs, Form G310* and *U.L. Roof Materials and Systems Directory*.

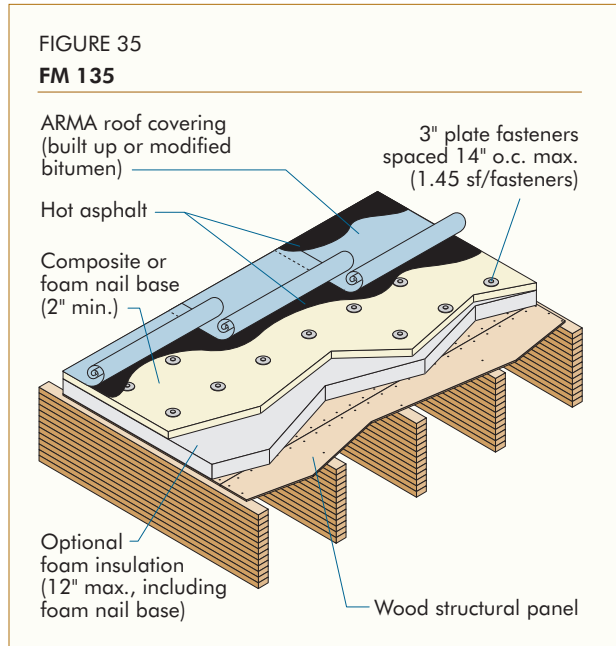
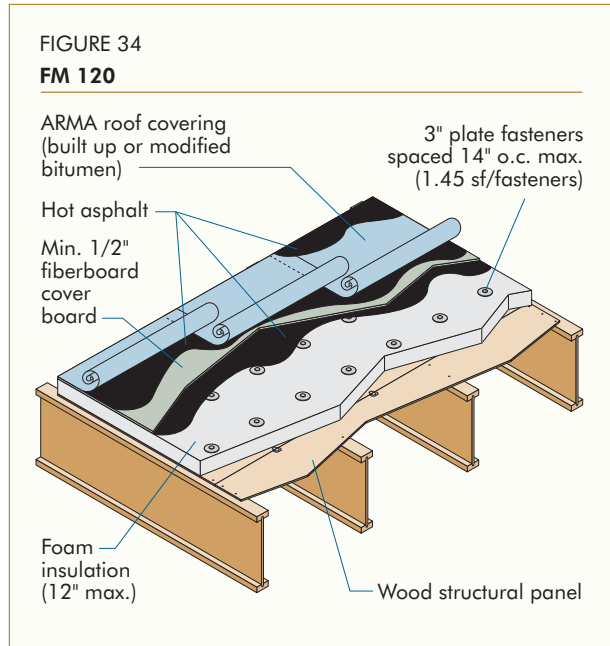
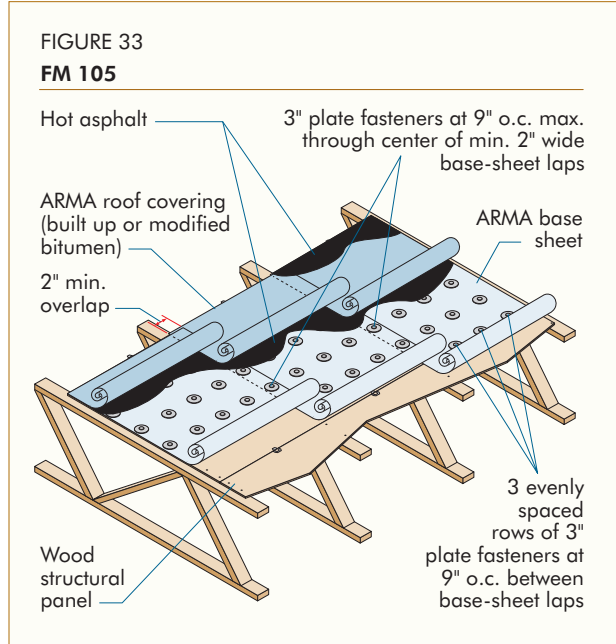
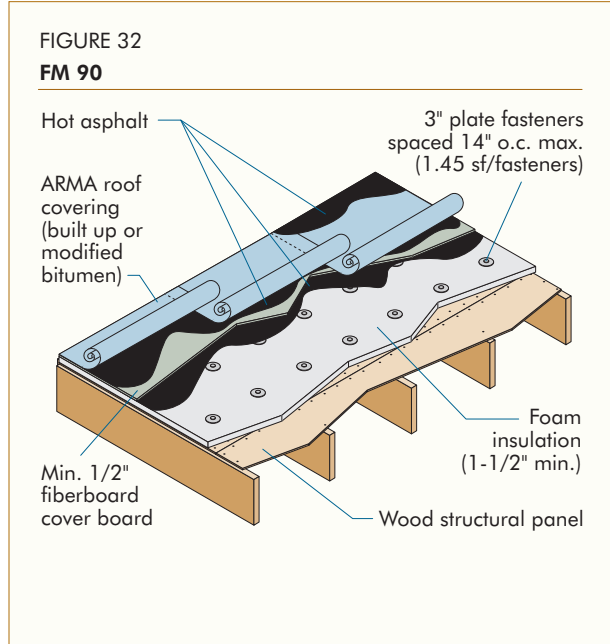
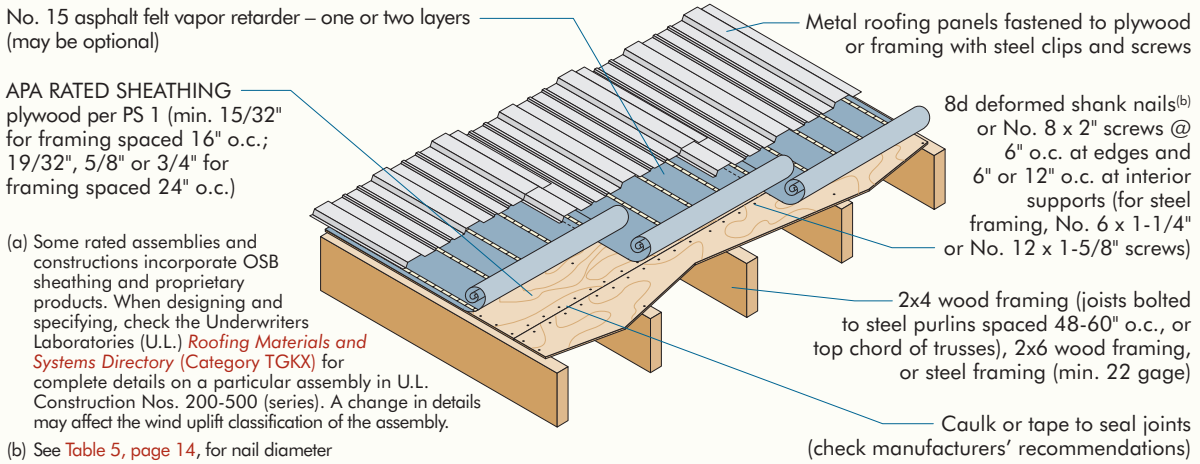

FIGURE 36

METAL ROOFING PANELS — UL CLASS 90^(a)



Noise Transmission Control

While some attention to sound control may be desirable in certain types of single-family residential buildings, it is mandatory in multifamily, commercial and industrial construction.

Selection of the correct noise-resistant surface and insulation assemblies is based on Sound Transmission Class (STC) and Impact Insulation Class (IIC). The STC rates a structural assembly's ability to reduce airborne noise. Most authorities agree that a multi-occupancy residential floor or wall should have an STC rating of at least 45, while over 50 is considered premium construction. Below 40, loud speech can be audible as a murmur and privacy and comfort are impaired. The level of background noise affects the choice of STC.

FIGURE 37

**NOISE-RESISTANT PARTY WALL
STC = 46**

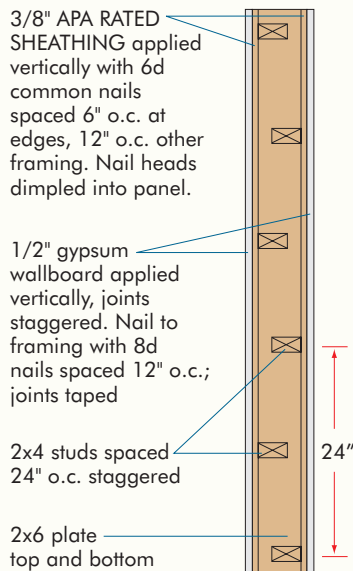
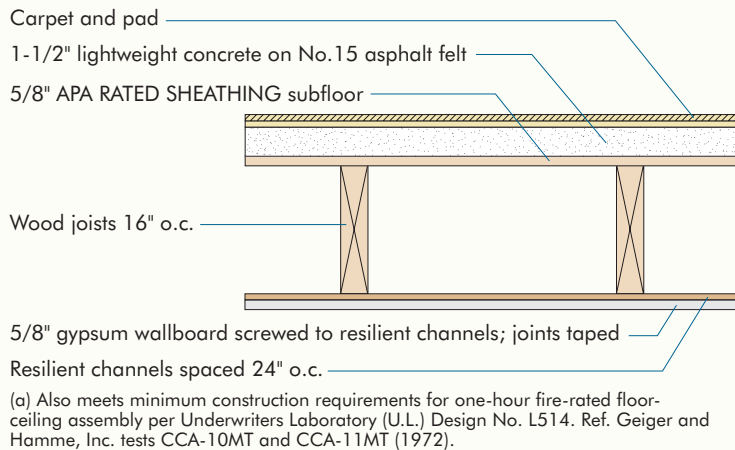

FIGURE 38

**NOISE-RESISTANT FLOOR ASSEMBLY^(a)
(Lightweight Concrete Over APA Panels) STC = 58; IIC = 73**



The IIC ratings define the capacity to control impact noise. In most cases, required IIC rating values are about the same as for STC.

Figures 37 and 38 show only two of the many sound-resistant floor and wall assemblies that can be obtained with wood structural panels. Some floor-ceiling assemblies also qualify as fire-rated construction.

While many listed assemblies were tested using plywood, other APA OSB and composite structural-use panels may be substituted on a thickness-for-thickness basis. Because of their similar strength and stiffness properties and slightly higher density, use of these products in lieu of plywood will not compromise the STC or IIC ratings of the tested systems.

For additional information, see *APA Design/Construction Guide: Noise-Rated Systems, Form W460*.

Energy Conservation

Insulating Exterior Walls

With adoption of more stringent energy-efficiency regulations, it is increasingly important to build walls to meet new requirements as efficiently as possible. Installation of APA RATED SHEATHING or APA RATED SIDING panels yields tight construction to minimize heat loss due to air infiltration. Framed walls also can be easily insulated to provide U values found in energy standards. Figure 39 illustrates two construction options and their corresponding U values.

FIGURE 39

ENERGY-CONSERVING WALL ASSEMBLIES

APA RATED LAP SIDING OVER WOOD STRUCTURAL PANEL SHEATHING

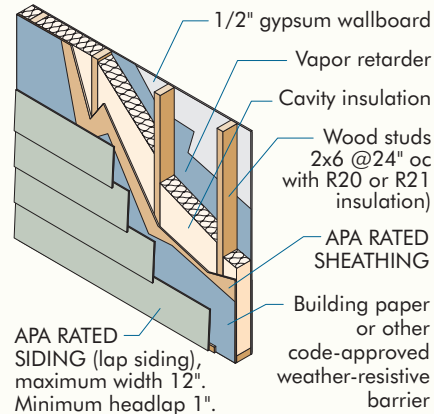

R	
Outside surface (15 mph wind)	0.17
APA RATED SHEATHING	0.43–0.78
Cavity insulation	
Option A – R20	20.00
Option B – R21	21.00
1/2" gypsum wallboard	0.45
Inside surface (still air)	0.68

Insulation Option	Average U ^(b)	Minimum Effective R = 1/U
A	0.061	16.27
B	0.060	16.70

APA RATED SIDING OVER RIGID FOAM INSULATION SHEATHING

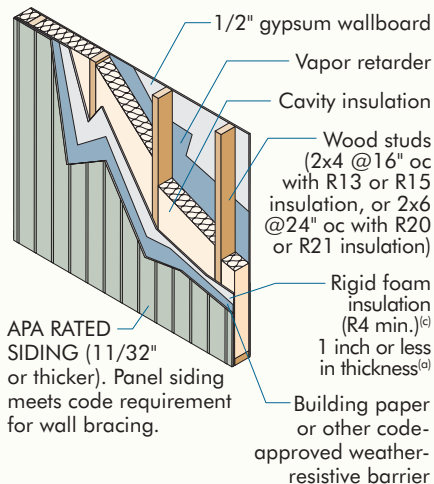

R	
Outside surface (15 mph wind)	0.17
APA RATED SIDING	0.43–0.78
Rigid foam insulation	4.00 (min.)
Cavity insulation	
Option C – R13	13.00
Option D – R15	15.00
Option E – R20	20.00
Option F – R21	21.00
1/2" gypsum wallboard	0.45
Inside surface (still air)	0.68

Insulation Option	Average U ^(b)	Minimum Effective R = 1/U
C	0.065	15.44
D	0.061	16.42
E	0.048	20.94
F	0.047	21.45

(a) See *APA Technical Note: APA Rated Siding Panels over Rigid Foam Insulation Sheathing, Form C465*.

(b) Average U values include adjustment for 25% framing area with studs spaced 16" o.c. When studs are spaced 24" o.c. (22% framing area), average U values are slightly lower and corresponding R values are higher. Average U value is based on R value at framing of 4.38 for 2x4 wood studs and 6.88 for 2x6 wood studs.

(c) Consult rigid foam manufacturer for R-value and panel permeability values. (See *APA Technical Topics: Wood Moisture Content and the Importance of Drying in Wood Building Systems, Form TT-111*).

One of the assemblies uses APA RATED SIDING (lap siding) over APA RATED SHEATHING and one shows siding panels applied over rigid foam insulation. Figure 39 shows the installation of the vapor retarder on the inside of the wall framing for typical construction. Local climatic conditions, energy codes or standard construction practices may vary the type or location of the vapor retarder.

For additional information, see *APA Design/Construction Guide: Build Energy Efficient Walls, Form J440*.

Insulating Panel Roofs

Insulating APA panel roof decks is simpler, quicker and less expensive than other decks since batt insulation can be applied on the underside of the deck when ventilation is provided – and roofing on top – without further preparation. Most metal roof systems, on the other hand, require special rigid insulation on top of the deck to provide the smooth surface needed for roofing. The panel deck with blanket insulation also provides better sound absorption, an important consideration in commercial, industrial and institutional construction.

A wood-frame panel-roof-deck system can be effectively insulated through a variety of techniques. Figure 40 shows four APA panel roof decks – three with insulation and one without. Average U values for below-deck insulation include adjustment for 8 percent framing area.

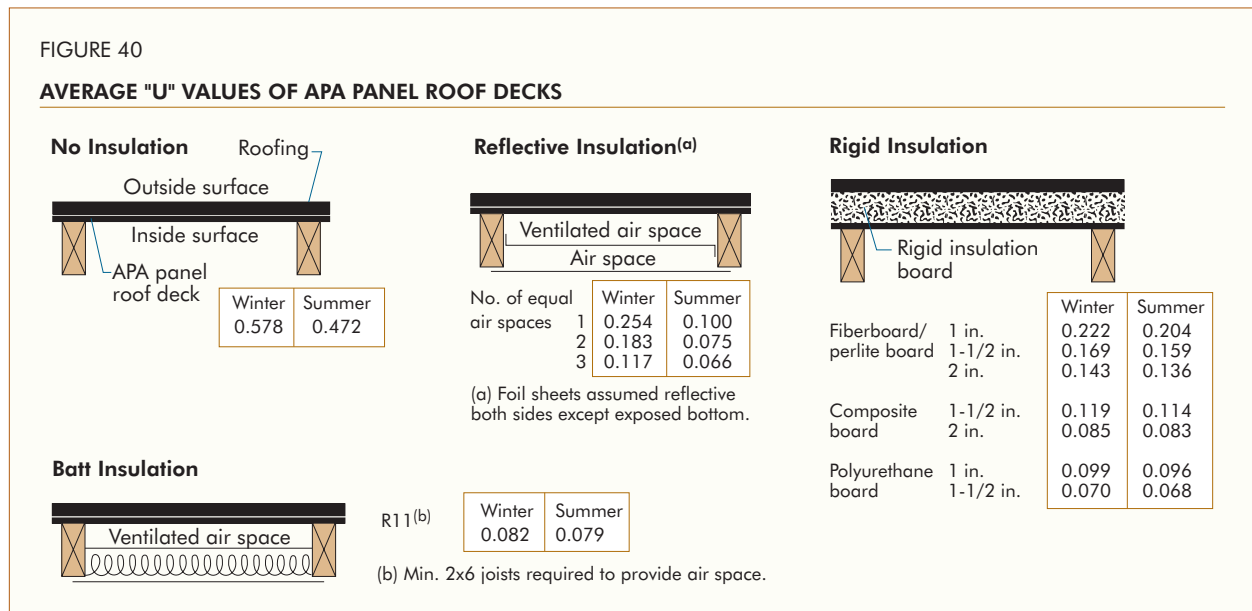

Condensation: Its Cause and Control

Today's construction techniques usually produce a far better sealed and insulated building than those built in the past. At the same time, the modern house is likely to be equipped with appliances that give off moisture. It is more important than ever, therefore, to provide adequate measures for controlling moisture and condensation. Lack of attention to this area may cause difficulties and costly callbacks.

Studies show that moisture originates both inside and outside the structure. Trouble may start with condensation on the underside of roof decking in the attic. Moisture transmission through walls can cause paint failures on exterior walls. The solution is adequate ventilation and properly placed moisture vapor retarders. Ceiling vapor retarders are typically omitted where attics are well ventilated. Local climatic conditions, energy codes or standard construction practices may make the actual presence or location of the vapor retarder vary.

Minimum ventilation requirements for both attic and crawl space appear in the International Residential Code and in other model building codes. The requirements are based on the ratio of the free ventilation area to the area to be ventilated. The required ratio is 1 to 150, applicable to both crawl spaces and attic areas. When a ground cover is placed in the crawl space, the crawl space ventilation ratio may be reduced*. The ratio in the attic area may also be reduced to 1 to 300 provided: 1) a vapor retarder is installed on the warm side of the ceiling, or 2) ventilation* is provided.

In general, condensation can be controlled with a vapor retarder placed on the warm side of the walls and below concrete slabs or as a ground cover in crawl spaces, along with adequate ventilation in attics and crawl spaces.

Ventilation should not be cut off at any time during the year when it is the only means of moisture control in crawl spaces. In cold climates, low temperatures beneath the first floor may be expected in a ventilated crawl space, and insulation will be required in the floor and around exposed mechanical lines. When a vapor retarder is installed for ground cover, vents may be closable and the perimeter foundation wall may be insulated in lieu of the floor.

Additional information concerning controlling mold and mildew may be found in *APA's Build A Better Home: Mold and Mildew, Form A525*.

Moisture control recommendations for low slope APA panel roof decks are described in *APA Technical Note: Moisture Control in Low Slope Roofs, Form R525*.

Additional information is available in *APA Technical Note: Controlling Decay in Wood Construction, Form R495* and *APA's Build A Better Home: Roofs, Form A535*.

*Refer to *APA Technical Note: Condensation Causes and Control, Form X485* for detailed information.

Thermal Resistance of Wood Structural Panels

For most wood structural panel applications, the most important thermal quality is resistance, or insulating effectiveness. While wood structural panels include plywood and OSB and can be made up of a number of different species, the thermal resistance property is relatively insensitive to such differences. For determining the overall coefficient of heat transmission (U), as illustrated in Figure 40, APA publications rely on the thermal resistance values for softwood published by the American Society of Heating, Refrigeration and Air Conditioning Engineers (ASHRAE). Use of this single value simplifies computations and produces only insignificant differences in resulting design heat losses. Table 42 shows thermal resistance, R, for several panel thicknesses.

TABLE 42

THERMAL RESISTANCE

Panel Performance Category	Thermal Resistance, R ^{(a)(b)}
1/4	0.31
5/16	0.39
3/8	0.47
7/16	0.55
15/32	0.59
1/2	0.62
19/32	0.74
5/8	0.78
23/32	0.90
3/4	0.94
7/8	1.09
1	1.25
1-1/8	1.41

(a) Degree F-hr.-sq.ft./BTU

(b) The tabulated thermal resistance (R) values are based on Douglas fir-Larch plywood at 8% moisture content and 75°F. For more information, refer to TenWolde, A, J.D. McNatt, and L. Krahn. 1988. *Thermal Properties of Wood and Wood Panel Products for Use in Building*. Report prepared for Oak Ridge National Laboratory. DOE/USDA-21697/1 and ORNL/Sub/87-21697/1. USDA Forest Products Laboratory, Madison, WI.

RELATED PANEL SYSTEMS

The Permanent Wood Foundation

The Permanent Wood Foundation (PWF), also referred to as the All-Weather Wood Foundation (AWWF), is made up of pressure-preservative-treated below-grade stud walls built of lumber and APA trademarked plywood. The system is accepted for FHA mortgage insurance programs. It's accepted by model building codes and most state and local codes. And, whether full basement or crawl space, the PWF is adaptable to almost any site and light-frame building design.

For complete design and construction recommendations, contact the American Wood Council, 803 Sycolin Road, Suite 201, Leesburg, Virginia 20175 (www.awc.org); or the Southern Pine Council, P.O. Box 641700, Kenner, Louisiana 70064 (www.southernpine.org).

Plywood for Outdoor Decks

Exterior-type plywood may be used in outdoor deck applications. Recommended grades include APA RATED STURD-I-FLOOR Exterior, C-C Plugged, Underlayment C-C Plugged, or Marine. Where the deck may be exposed to long-term dampness, such as applications where the plywood is topped with outdoor carpet, the plywood should be pressure-preservative-treated with a waterborne preservative in accordance with [AWPA U1 Standard with a UC3B](#) or higher designation. For optimum performance, slope the deck away from the structure. A slope of 1/4 to 1/2 inch per foot is suggested.

Space panels 1/8 inch at ends and edges to allow for expansion. Caulk the joints to prevent water leakage into areas underneath. To avoid fastener corrosion, use hot-dip, hot-tumbled galvanized or stainless steel nails. If the underside of the joists is covered, the floor-ceiling cavity should be vented to aid in drying and to prevent potential moisture buildup in the deck.

If there is a dry living area underneath the deck, apply a membrane roof covering or high performance coating over the surface. The coating should be able to accommodate normal dimensional changes in the plywood without rupturing or cracking. Under these conditions, APA RATED STURD-I-FLOOR Exposure 1 may be used unless otherwise recommended by the coating manufacturer, and preservative treatment of the panels is not necessary.

Corrosion resistant fasteners and connectors are required for most applications using pressure-preservative-treated wood. Refer to [APA Technical Note: Corrosion-Resistant Fasteners, Form D485](#) and [APA Data File: Preservative-Treated Plywood, Form Q220](#) for detailed information.

Plywood for Concrete Forming

Plywood is an ideal material for concrete forming. It produces smooth concrete surfaces and can be used repeatedly – some overlaid panels up to 200 times or more. The thinner panels can be bent easily for curved forms and liners. Plywood's excellent stiffness minimizes deflection during pouring. Its natural insulating qualities help provide more consistent curing conditions. The large panel size and light weight reduce form construction and stripping time. And various surface textures are available for imparting attractive and unusual concrete textures.

Although nearly any Exterior plywood can be used for concrete forming, a special panel called PLYFORM® Class I is manufactured specifically for the purpose. PLYFORM also can be manufactured with a High Density Overlay (HDO) surface, and in Structural I panels. HDO PLYFORM has an exceptionally hard surface for the smoothest possible concrete finishes and maximum number of pours. Structural I PLYFORM is stronger and stiffer than PLYFORM Class I, particularly in the cross-panel direction, and is sometimes used for high pressures where long dimension is parallel to supports. Additional plywood grades designed for concrete forming include special overlays and proprietary panels.

For complete design information, refer to [APA Design/Construction Guide: Concrete Forming, Form V345](#).

Structural Insulated Panels

The structural insulated panel (SIP) offers the stiffness and load handling capability of a stressed-skin panel, plus light weight, high insulation values for relatively small thicknesses, and fast panelized construction. Panels are prefabricated by sandwiching an insulating core material, such as polystyrene or polyurethane foam, between wood structural panel “skins.” A structural bond is formed between the core and the skins with structural adhesives or, in the case of some foam materials, by direct adhesion of foam to the skins.

With APA panel siding over the outside skin, structural insulated panels make attractive, energy-conserving walls on both residential and commercial buildings. A typical structural insulated wall panel will have Performance Category 7/16 wood structural panel skins on both faces. Check local building requirements relating to thermal barrier protection of plastic foam. For additional information, refer to *APA Product Guide: Structural Insulated Panels, Form H650*, or contact the Structural Insulated Panel Association (SIPA) at their website: www.sips.org.

APA Panels Over Metal Framing

Modern fastening methods permit the use of APA panels over metal framing. Self-drilling, self-tapping fasteners commonly are used to attach panels with a Performance Category up to 1-1/8 to steel flanges. Panels also can be fastened to lighter members, such as formed steel joists, with pneumatic or powder tools and special hardened screw-shank nails or pins. Construction adhesives are recommended with hardened screw-shank nails. Consult metal-framing manufacturers for recommended adhesives. Since threads usually extend only part way up the shank of self-drilling, self-tapping screws and screw-shank nails, it is important to specify a length sufficient to engage the metal framing.

Typical panel-to-metal framing systems are illustrated in Figure 41. Load-span recommendations

are the same as for wood-frame systems. For more information, refer to *APA Design/Construction Guide: Wood Structural Panels Over Metal Framing, Form T625*.

APA Panel Systems Over Concrete Slabs

A system of APA panels over sleepers embedded in mastic has been successfully installed over concrete slabs. Tongue-and-groove panels eliminate the need for blocking between sleepers at panel edges and allow air circulation beneath the floor. A vapor barrier is essential directly above or below the slab. Preservative treatment of the sleepers is recommended when the slab is on or below grade, although panels normally will not require treatment.

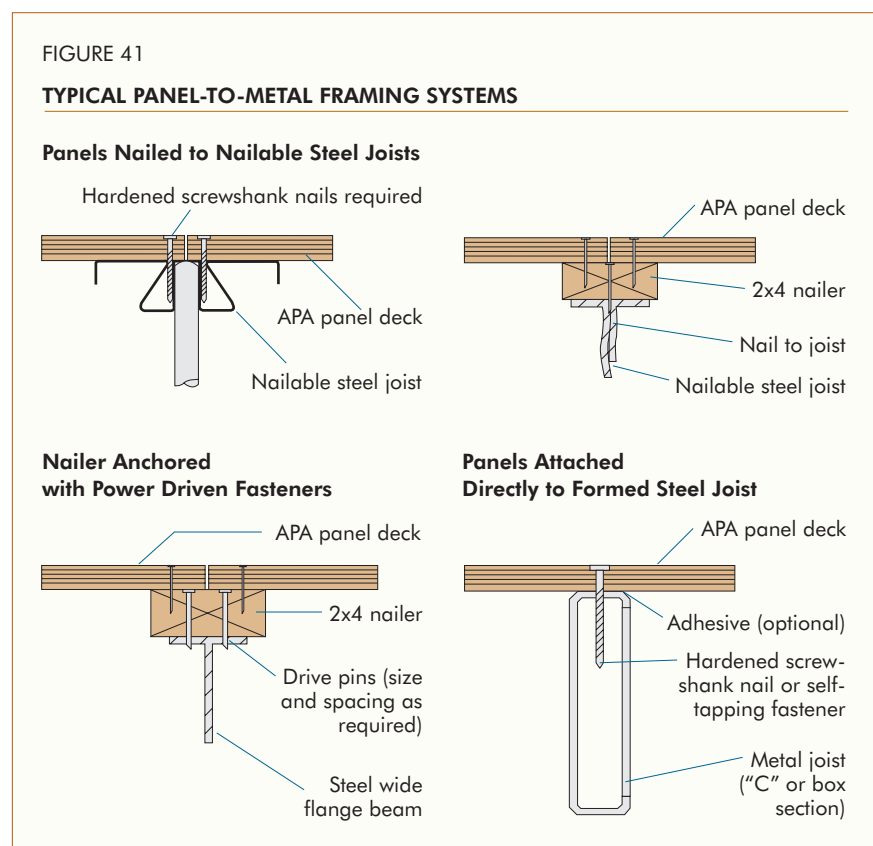

Tongue-and-groove plywood can be installed over polystyrene or polyurethane foam. The foam, bonded to both the plywood and concrete slab with mastic, provides high insulating value and resistance to termites, rot and fungus. Exterior plywood with a Performance Category of at least 19/32 is recommended. A vapor barrier, such as polyethylene, is required either directly above or below the concrete slab.

Special Floor Surfacing

Hardboard overlaid plywood (APA PLYRON®) is sometimes used as a finish floor, especially for industrial installation. (Check your local dealer for availability.) High Density Overlay (HDO) panels with a special heavy-duty screen-grid surface provide skid-resistant, long-wearing surfaces under foot traffic. And a number of liquid coatings – some suitable for balconies, porches, patio decks and other exterior applications – are also available.

ADDITIONAL INFORMATION

About APA – The Engineered Wood Association



APA – *The Engineered Wood Association* is a nonprofit trade association of and for structural wood panel, glulam timber, wood I-joint, structural composite lumber, and other engineered wood product manufacturers. Based in Tacoma, Washington, APA represents approximately 150 mills throughout North America, ranging from small, independently owned and operated companies to large integrated corporations.

Always insist on engineered wood products bearing the **mark of quality** – the APA or APA EWS trademark. Your APA engineered wood purchase is not only your highest possible assurance of product quality, but an investment in the many trade services that APA provides on your behalf. The Association's trademark appears only on products manufactured by member mills and is the manufacturer's assurance that the product conforms to the standard shown on the trademark.

For panels, that standard may be the [Voluntary Product Standard PS 1-09 for Structural Plywood](#), [Voluntary Product Standard PS 2-10, Performance Standards for Wood-Based Structural-Use Panels](#) or [APA PRP-108 Performance Standards and Qualification Policy for Structural-Use Panels](#). Panel quality of all APA trademarked products is subject to verification through APA audit.

The APA or APA EWS trademark appears only on engineered wood products manufactured by members of APA. The mark signifies that the manufacturer is committed to a rigorous program of quality verification and testing and that products are manufactured in conformance with an APA or national standard such as [ANSI/AITC A190.1, Standard for Structural Glued Laminated Timber](#); [ANSI/APA PRP 210, Standard for Performance-Rated Engineered Wood Panel Siding](#); [APA PRI-400, Performance Standard for APA EWS I-Joists](#); [ANSI/APA PRR 410, Standard for Performance-Rated Engineered Wood Rim Boards](#); or with a manufacturer's building code evaluation report or APA Product Report (www.apawood.org/ProductReports).

APA's services go far beyond quality testing and inspection. Research and promotion programs play important roles in developing and improving construction systems using wood structural panels, glulam, I-joists, and structural composite lumber, and in helping users and specifiers to better understand and apply engineered wood products. For more information, please see the back cover.

Engineered Wood Construction Guide

APA offers a comprehensive set of services and tools for design and construction professionals specifying and using engineered wood products and building systems. If you're looking for detailed product information, training material, or technical assistance, APA can help.

- ▶▶▶▶ www.apawood.org, APA's website, is your link to in-depth design and building support, including a library of more than 400 publications available for instant pdf download or hard-copy purchase.
- ▶▶▶▶ help@apawood.org or (253) 620-7400 is your connection to the APA Product Support Help Desk. Staffed by specialists who have the knowledge to address a diverse range of inquiries related to engineered wood, the Help Desk can answer your questions about specification and application of APA products.

Tap into APA's extensive knowledge and resources.

- Training materials and assistance, including Wood University, APA's online portal for engineered wood education, located at www.wooduniversity.org
- Information to protect homes against damaging moisture infiltration through the Build a Better Home and Free From Mold programs, including guides and details for builders at www.buildabetterhome.org and an inspection regimen for homeowners at www.freefrommold.org
- More than 200 downloadable CAD details, found at www.apacad.org
- Field representatives in many major U.S. cities and Canada who can answer questions about APA trademarked products

For a list of APA and APA EWS publications, download the *APA Publications Index*, Form B300, at www.apawood.org/publications.

APA – THE ENGINEERED WOOD ASSOCIATION HEADQUARTERS

7011 So. 19th St. Tacoma, Washington 98466 ■ (253) 565-6600 ■ Fax: (253) 565-7265

DISCLAIMER

The information contained herein is based on APA – The Engineered Wood Association's continuing programs of laboratory testing, product research, and comprehensive field experience. Neither APA, nor its members make any warranty, expressed or implied, or assume any legal liability or responsibility for the use, application of, and/or reference to opinions, findings, conclusions, or recommendations included in this publication. Consult your local jurisdiction or design professional to assure compliance with code, construction, and performance requirements. Because APA has no control over quality of workmanship or the conditions under which engineered wood products are used, it cannot accept responsibility of product performance or designs as actually constructed.



www.apawood.org



Form No. E30V/Revised August 2011/1200

