

TOLKO

TECHNICAL GUIDE (ASD - USA)

T-TEC LSL STAIR STRINGER 1-1/4" 1.35E

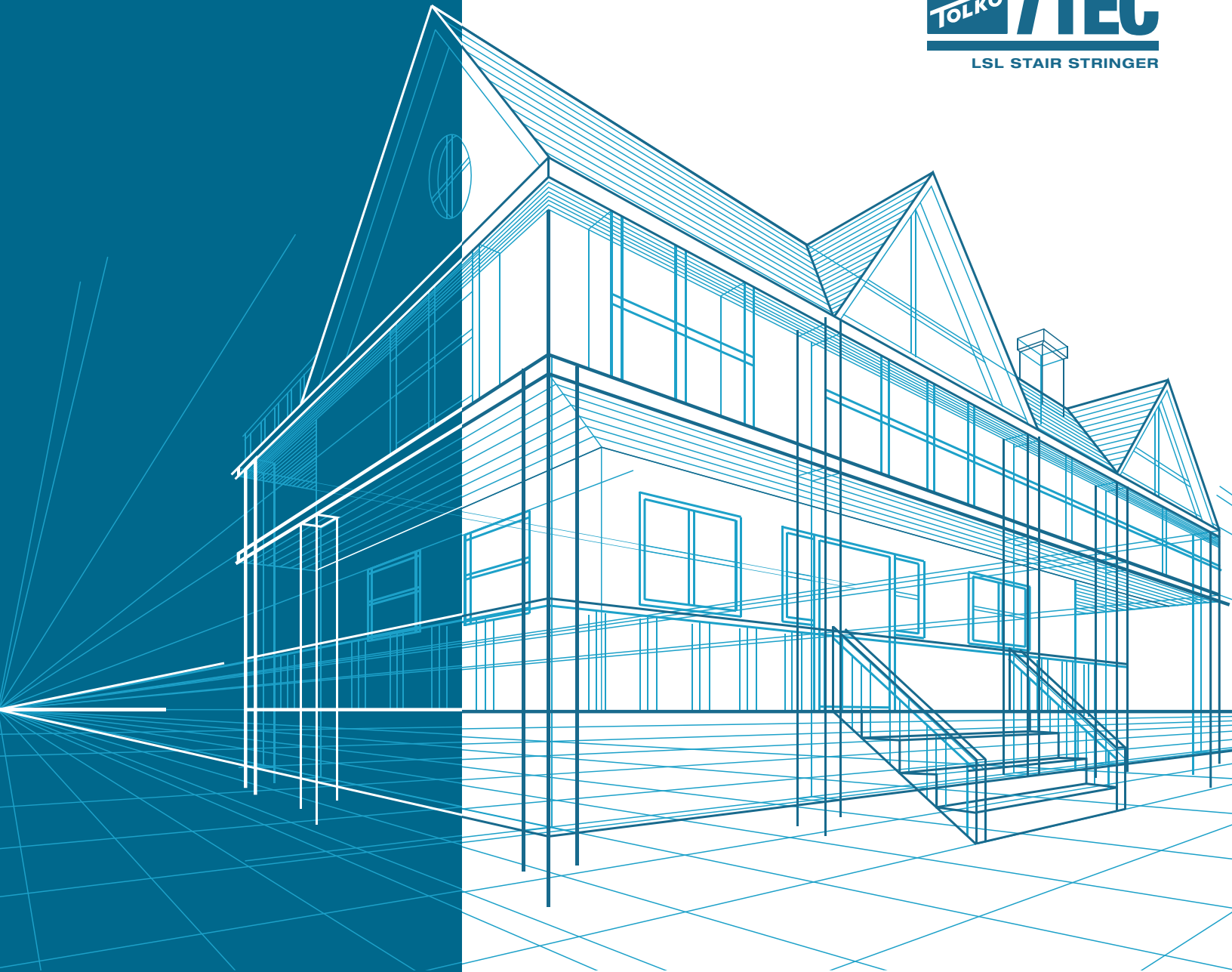

**TRUE.
TRUSTED.
TOLKO.**

Tolko Marketing and Sales
3000 - 28th Street
Vernon, BC V1T 9W9
Tel 250.545.4411 - Fax 250.550.2550



ALLOWABLE STRESS DESIGN
Published: Oct. 29, 2018

WWW.TOLKO.COM



TOLKO T-TEC LSL PRODUCTS

Tolko's line of Laminated Strand Lumber (LSL) is manufactured from strands of fibre selected to create a solid, consistent, and uniform alternative to traditional structural and non-structural products such as lumber, plywood, OSB and LVL. There is no warp, no wane, and no rot which means no waste and no need to order extra materials.

CREATING VALUE FROM THE STRANDS

Tolko LSL products are produced at our Athabasca mill in Slave Lake, Alberta. This industry-leading facility has the longest continuous press in North America, ensuring a steady stream of uniform engineered wood products and precise mixtures for product consistency and dimensional accuracy. Our continuous press provides contractors with the confidence that T-TEC LSL will perform as intended at every job.

DELIVERING VALUE WITH CONSISTENCY

Our Athabasca Mill is serviced by a combination of truck and rail providing Tolko with the flexibility to reach customers across Canada and the USA.

ACHIEVING VALUE WITH 1.35 E-RATING

The E-Rating of engineered wood products identifies the modulus of elasticity (MOE) or the tendency of the product to deform along an axis when opposing forces are applied. A greater E-Rating means the product is more resistant to changing with force.

WHY CHOOSE T-TEC LSL?

- ✓ Reduce materials and enhance design
- ✓ Improve recovery
- ✓ Reduce installation time
- ✓ Build quieter floors and straighter walls
- ✓ Protect against fungal decay and insects
- ✓ Earn Green Building credits

INQUIRE TODAY

EWP Sales

Phone: 250-549-5311

Email: EWPSales@tolko.com

Website: www.tolko.com

CONTENTS

Figure 1:	Residential Stair Stringer Design	1
Table 1:	1.35E Tolko T-TEC LSL: Allowable Edgewise Design Properties ^(a)	1
Figure 2:	Stairway Design	1
Figure 3:	Stair Detail	2
Figure 4:	Stair Parts/Connectors	2
Figure 5:	Two or Three Stair Stringers Applications	2
Figure 6:	Simple or Multiple Span Stair Stringers Configurations	2
Table 2:	Stringer Connectors: Upper Ends	3
Table 3:	Stringer Connectors: Lower Ends	3
Table 4:	1.35E Tolko T-TEC LSL 1-1/4" Maximum Stringer Run	3
	Warnings	4
	Storage and Handling	5

FIGURE 1: RESIDENTIAL STAIR STRINGER DESIGN

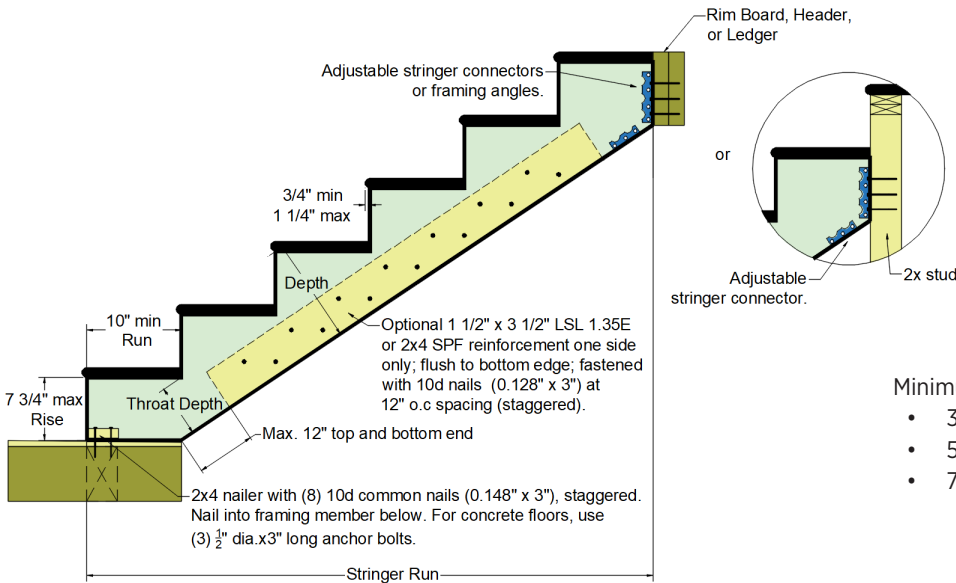

Minimum throat depth:

- 3-1/2" for 1.35E T-TEC LSL 1-1/4" x 9-1/2"
- 5-3/4" for 1.35E T-TEC LSL 1-1/4" x 11-7/8"
- 7-7/8" for 1.35E T-TEC LSL 1-1/4" x 14"

TABLE 1: 1.35E TOLKO T-TEC LSL: ALLOWABLE EDGEWISE DESIGN PROPERTIES^(a)

Product/Grade	Modulus of Elasticity, E ^(b) (psi)	Flexural Stress, Fb ^(b) (psi)	Compression Perpendicular to Grain, Fc _⊥ (psi)	Horizontal Shear Parallel to Grain, Fv (psi)
1.35E Tolko T-TEC LSL	1.35 X 10 ⁶	1850 ^(c)	750	330

(a) The tabulated values are design values for normal load duration. All values, except E and Fc_⊥, are permitted to be adjusted for other load durations as permitted by the code. The design stresses are limited to conditions in which the average equivalent moisture content of sawn lumber does not exceed 16 percent.

(b) Tabulated flexural stress (Fb) may be increased by 4 percent when the member qualifies as a repetitive member as defined in National Design Specifications 2018.

(c) Tabulated value is based on a reference depth of 12 inches. For other depths, when loaded edgewise, Fb shall be modified by (12/d)^{0.125}, where d = depth in inches.

(d) For a simple span member, deflection for a uniform load could be calculated as follows:

- where:
- δT = total deflection (in)
 - w = applied uniform loads (lb/ft)
 - L = design span (ft)
 - E = modulus of elasticity (lb/in²)
 - b = beam width (in)
 - h = beam depth (in)

$$\delta_T = \frac{270wL^4}{Ebh^3}$$

WARNING

Drilling, sawing, sanding or machining wood products can expose you to wood dust, a substance known to the State of California to cause cancer. Avoid inhaling wood dust or use a dust mask or other safeguards for personal protection. For more information go to www.P65Warnings.ca.gov/wood.

WARNING

This product can expose you to chemicals including methanol, which is known to the State of California to cause birth defects or other reproductive harm. For more information go to www.P65Warnings.ca.gov.

FIGURE 2: STAIRWAY DESIGN

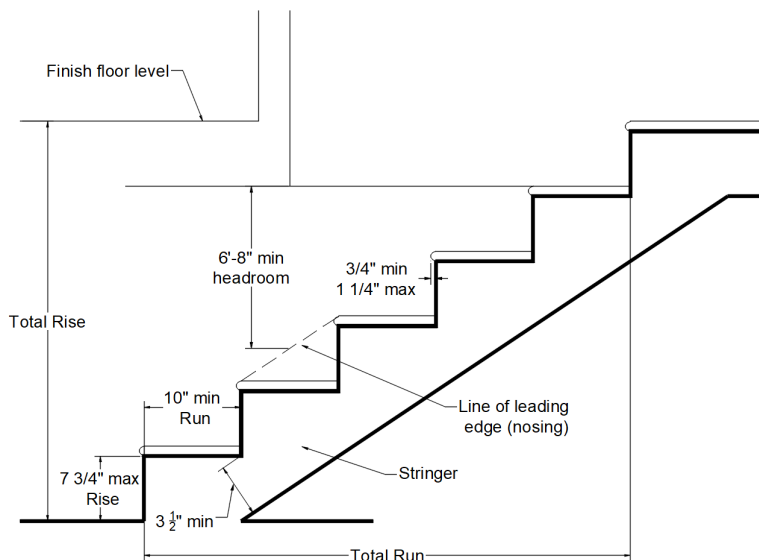

Notes:

- 1) Stairways shall not be less than 36 inches in clear width.
- 2) The headroom shall not be less than 6 feet 8 inches measured vertically from the line of leading edge (nosing).
- 3) The U.S. building codes established that the riser height shall not be more than 7-3/4" and the run shall be minimum 10". Check with the local building codes if these limits are more restrictive.
- 4) The riser shall be measured vertically between leading edges of the adjacent treads. The greatest riser height within any flight of stairs shall not exceed the smallest by more than 3/8 inch.
- 5) The run is the horizontal distance measured from riser to riser.
- 6) The tread is the horizontal plane of a step.
- 7) The greatest tread depth (run + nosing) within any flight of stairs shall not exceed the smallest by 3/8 inch.
- 8) Stair stringer shall be protected by a vapor barrier if it is in contact with concrete.
- 9) The length or width of any landing must not be less than the width of the stairs.
- 10) Maximum total rise between floors should be 12'-0" as permitted by the building code.
- 11) For stair configurations not shown, contact your Tolko representative.

FIGURE 3: STAIR DETAIL

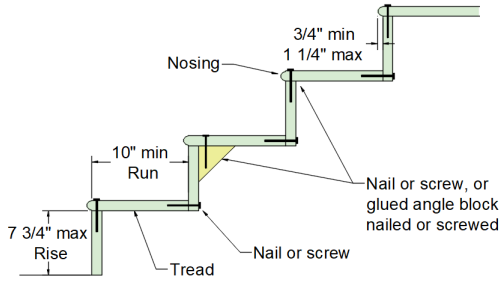

Notes:

- 1) A rise of 7 to 7-1/2 in. with a run of about 10 to 10-1/4 in. could combine both comfort and safety.
- 2) The number of risers = Total rise/rise, rounded up to the next integer. Example: Total rise = 8ft 11 in.; rise = 7-1/4"; total number of risers = 107/7.25 = 14.8; rounding up, 15 risers will be required at 7.13 in., where 107/15 = 7.13 in.
- 3) The number of runs = number of risers - 1. The run is determined by dividing the Total Run by the number of runs.

FIGURE 4: STAIR PARTS/CONNECTORS

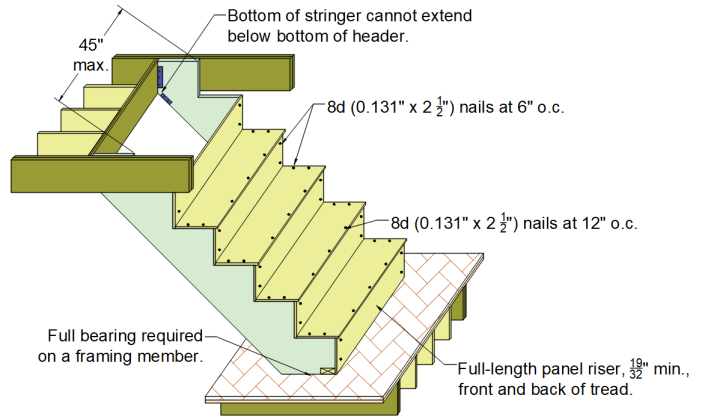

Notes:

- 1) The treads and risers must be solidly supported, firmly fixed, and properly positioned on the stringer.
- 2) The stringers must be properly supported on a framing member at the lower end.
- 3) Bottom of stringer shall not extend below bottom of header at the upper end.

FIGURE 5: TWO OR THREE STAIR STRINGERS APPLICATIONS

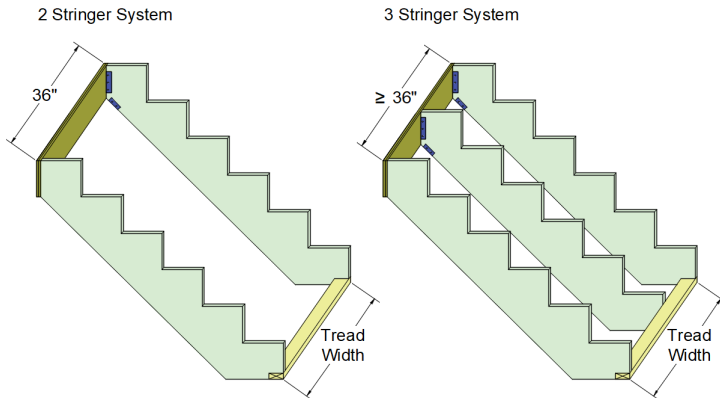

Note:

- 1) A third stringer is required when the width of the stairs is more than 36 in.

FIGURE 6: SIMPLE OR MULTIPLE SPAN STAIR STRINGERS CONFIGURATIONS

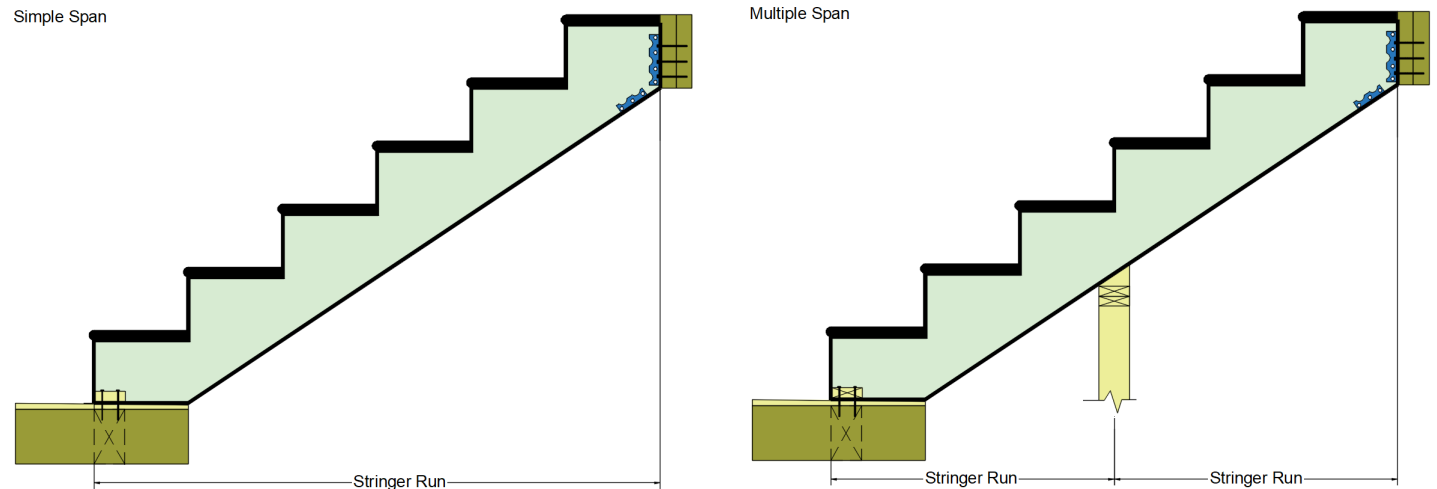

Note:

For multiple span stringers, the interior support should be able to transfer an axial load of 1000 lbs for the 40/12 psf loading conditions and an axial load of 2000 lbs for the 100/12 psf loads.

TABLE 2: STRINGER CONNECTORS: UPPER ENDS

Stringer Upper End Connectors	Model No.	Fastener Schedule		
		Rim Board or Supporting Member	Stringer Wide Face	Stringer Narrow Face
Adjustable stringer connectors	Simpson Strong-Tie® LSCZ, LSCSS	(8) 10d x 1 1/2"	(8) 10d x 1 1/2"	(1) 10d x 1 1/2"
		(8) SD #9 x 1 1/2"	(8) SD #9 x 1 1/2"	(1) SD #9 x 1 1/2"
	Mitek® CSH-TZ	(8) 10d x 1 1/2"	(3) 10d x 1 1/2"	(2) 10d x 1 1/2"
Framing angles	Simpson Strong-Tie® LS70, LS90	(5) 10d x 1 1/2"	(5) 10d x 1 1/2"	-
	Simpson Strong-Tie® A35	(6) 8d x 1 1/2"	(6) 8d x 1 1/2"	-
	Mitek® MPA1	(6) 8d x 1 1/2"	(6) 8d x 1 1/2"	-

- Notes:**
- 1) 10d x 1 1/2" = 0.148" dia. X 1 1/2" long. Nails shall be hot-dip galvanized for LSCZ and stainless steel LSCSS.
 - 2) SD #9 x 1 1/2" (model SD9112) = 0.131" dia. X 1 1/2" long (LSCZ only).
 - 3) 8d x 1 1/2" = 0.131" dia. x 1 1/2" long.
 - 4) Tabulated connectors shall be only used for the 40/12 psf loads or for the 100/12 psf loads with 3 stringers, with the exception of the LSCZ, LSCSS, and CSH-TZ, which could be used for the 100/12 psf loads with 2 stringers.
 - 5) Connectors shall be installed at mid-height or above the mid-height of the supporting member.
 - 6) LSCZ, LSCSS, and CSH-TZ will protrude 1/4" from the face of stringer. Therefore, the adjustable stringer connector shall be installed with the tabs positioned to the outside of the stringer. The 1 1/2" fasteners will also protrude from the opposite side.
 - 7) Stringer must be constrained from rotation since the connector is installed on one side only.
 - 8) Tabulated connectors shall not be installed within the cantilever for the supporting member.
 - 9) Tabulated connectors shall be installed only on one side.

TABLE 3: STRINGER CONNECTORS: LOWER ENDS

Stringer Lower End Connectors	2x4 nailer with (8) 10d common nails (0.148" x 3"), staggered. Nail into framing member below.
	For concrete floors, use (3) 1/2" dia. X 3" long anchor bolts.

TABLE 4: 1.35E TOLKO T-TEC LSL 1-1/4" MAXIMUM STRINGER RUN

Maximum Stringer Run for 1.35E Tolko T-TEC LSL										
Material Depth (in)	36" Tread Width				42" Tread Width		44" Tread Width		48" Tread Width	
	2 Stringers		3 Stringers		3 Stringers		3 Stringers		3 Stringers	
	Reinforcement		Reinforcement		Reinforcement		Reinforcement		Reinforcement	
	No	Yes	No	Yes	No	Yes	No	Yes	No	Yes
40 PSF Live Load/12 PSF Dead Load										
9.5	5'-3"	6'-6"	6'-0"	7'-6"	5'-9"	7'-1"	5'-7"	7'-0"	5'-6"	6'-9"
11.875	8'-7"	9'-3"	9'-10"	10'-6"	9'-4"	10'-0"	9'-3"	9'-10"	9'-0"	9'-7"
14	11'-10"	12'-1"	13'-7"	14'-0"	12'-10"	13'-3"	12'-9"	13'-0"	12'-4"	12'-7"
100 PSF Live Load/12 PSF Dead Load										
9.5	3'-10"	4'-6"	4'-4"	5'-6"	4'-1"	5'-1"	4'-1"	5'-1"	4'-0"	4'-10"
11.875	6'-4"	6'-9"	7'-3"	7'-9"	6'-10"	7'-4"	6'-9"	7'-3"	6'-7"	7'-0"
14	8'-9"	9'-0"	10'-0"	10'-3"	9'-6"	9'-9"	9'-4"	9'-7"	9'-1"	9'-3"

- Notes:**
- 1) Spans based upon stair limits of 7.75" max. rise and 10" min. run valid for the U.S. building codes.
 - 2) Consult with the local building code for restrictions on risers and runs dimensions.
 - 3) Consult a design professional if the above rise and run limits are exceeded.
 - 4) Deflection criteria of L/360 live load and L/240 of total load.
 - 5) Tabulated values are only valid for the specified uniform loads.
 - 6) Tabulated values are based on a 100% load duration.
 - 7) Stringer self-weight was included in the analysis.
 - 8) For stringers with an interior support (multiple span stringers), the interior support should be able to transfer an axial load of 1000 lbs for the 40/12 psf loading conditions and an axial load of 2000 lbs for the 100/12 psf loads.
 - 9) Stringers are not stable until treads and risers are securely in place.
 - 10) Tabulated values are only valid for dry service conditions, where the moisture content in service does not exceed 16%, as in most covered structures.
 - 11) A vapor barrier shall be installed at the bottom of the stringer if the stringer is in contact with concrete.

WARNINGS

WARNING DETAIL 1: Do not install the stair stringer connectors below the header neutral axis

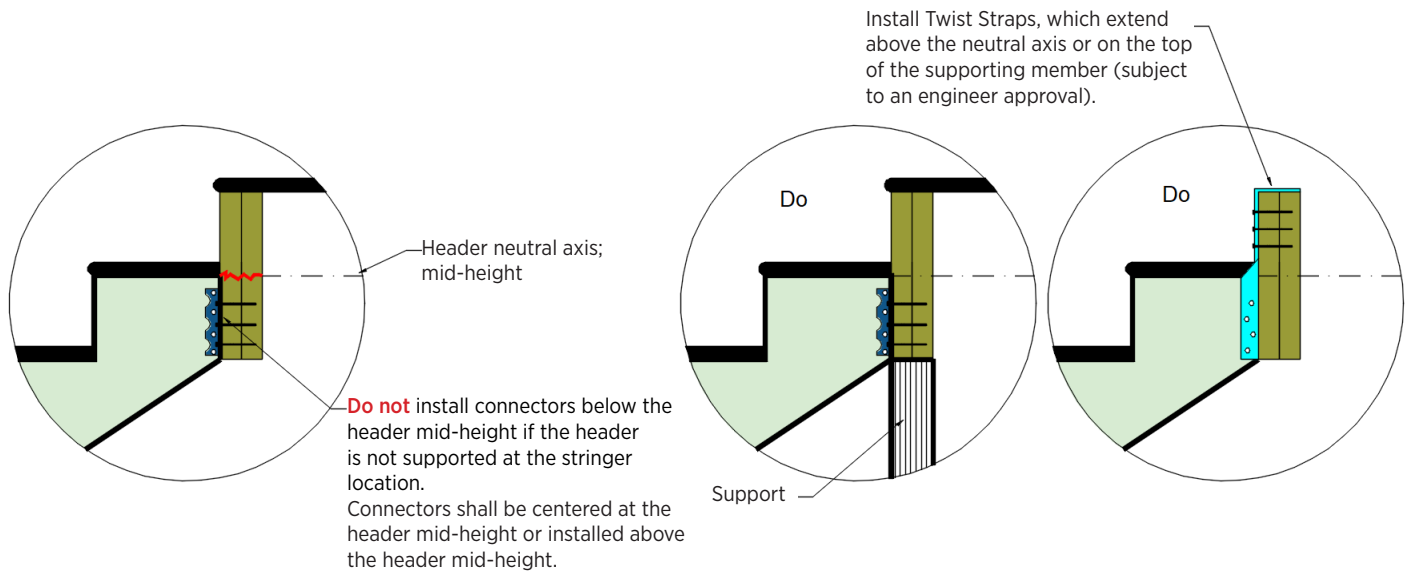

WARNING DETAIL 2: Do not support stair stringer on notch

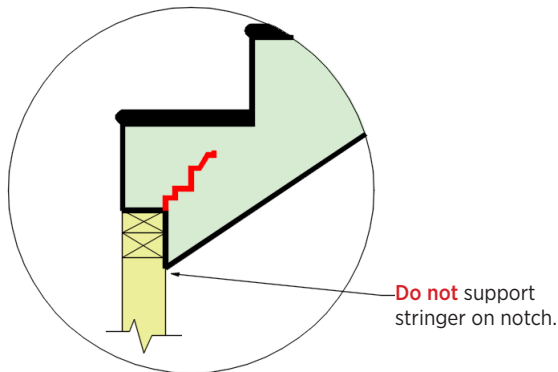

WARNING DETAIL 3: Full bearing required on the bottom of the stair stringer

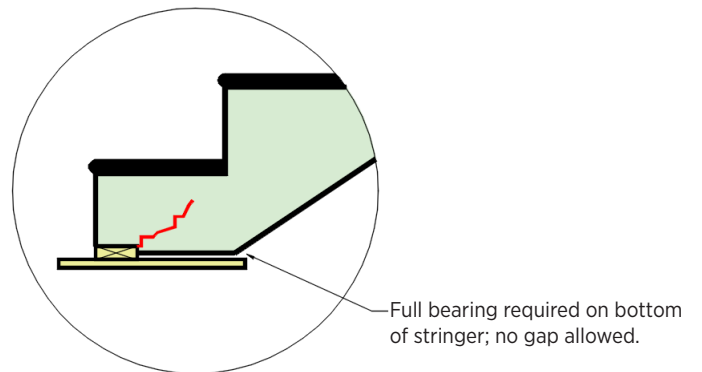

WARNING DETAIL 4: Do not overcut the stair stringer

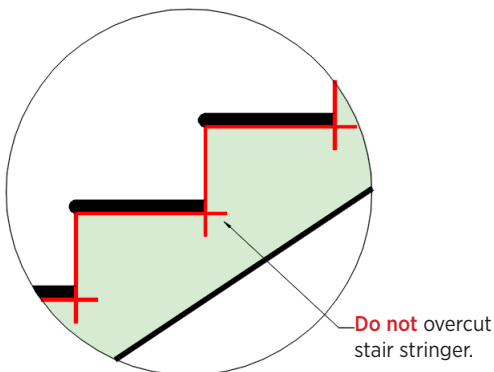

WARNING DETAIL 5: Do not extend the stair stringer bottom below the bottom of the header

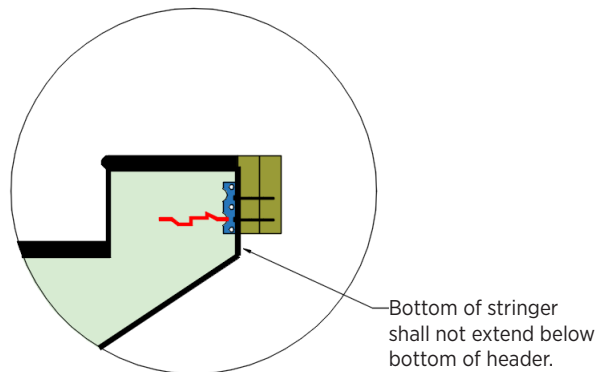

STORAGE AND HANDLING

INTRODUCTION

Proper storage and handling of engineered wood products (EWP) including T-TEC LSL and Tolko LSL Industrials is required to protect the products during distribution and at the jobsite. APA – The Engineered Wood Association recommends the following storage and handling practices for EWP products. For full details on proper storage and handling, refer to *APA Technical Note: Proper Storage and Handling of I-Joists and LVL, Form E705* available at www.apawood.org.

SAFE HANDLING DURING DISTRIBUTION

1. Bundle wrap can be slippery. Avoid walking on wrapped bundles. Stacks of product may be unstable or slippery, especially when wet. Avoid walking on the material.
2. Follow good forklift safety procedures when handling T-TEC LSL and Tolko LSL Industrials at the yard.
3. Store longest material lowest to the ground.
4. When handling with a crane, pick up the load using a spreader if necessary to minimize handling stresses.
5. Post and follow load limits on storage racks.

STORAGE DURING DISTRIBUTION

1. Keep wrapped to protect from weather.
2. Use stickers to separate bundles.
3. Use stickers every 8 feet and maintain vertical alignment of the stickers.
4. Do not store T-TEC LSL and Tolko LSL Industrials in direct contact with the ground.
5. For optimal moisture protection, keep at least 12 inches up from the ground.
6. To protect from dirt and weather, delay unwrapping the bundles until the time of the installation or cut-up for delivery.
7. Take care to avoid forklift damage. If the ground is unlevel in the storage area, reduce forklift speed to avoid “bouncing” the load.
8. When handling with a crane, pick up the load using a spreader if necessary to minimize handling stresses.
9. Maintain stack height within safe limits.
10. Do not stack other material on top of T-TEC LSL and Tolko LSL Industrials.

PROPER HANDLING AT THE JOBSITE

1. Do not drop the product off the delivery truck. Best practice is to use a forklift or boom.
2. Store on level, well-drained area.
3. Keep on stickers spaced every 8’ and at least every 6” off the ground at the jobsite.
4. Keep material covered to protect from weather.
5. Do not stack other material on top of the product.
6. Never use or try to repair damaged products. If defective material is discovered prior to or during installation, cease installation and contact the supplier.

MOISTURE EFFECTS

T-TEC LSL and Tolko LSL Industrials products are manufactured under carefully controlled conditions that assure they are dry. Moisture content can be affected by humidity, exposure to wetting and drying conditions. While T-TEC LSL and Tolko LSL Industrials products are engineered to withstand normal exposure, excessive exposure to moisture may lead to dimensional change.

If moisture is present, mold, mildew and wood decay fungi may grow on any engineered wood products, thus it is important to properly store T-TEC LSL and Tolko LSL Industrials to control exposure to moisture. Moisture increase is expected under normal construction situations and does not adversely affect the performance of the products if good building practices are followed to minimize exposure and to provide proper conditions for the products to re-equilibrate to dry conditions.

Reference: *APA Technical Note: Proper Storage and Handling of I-Joists and LVL, Form E705* available at www.apawood.org.

CSD SOFTWARE

Calculated Structured Designs Inc. (CSD®) is a software development company providing solutions for the engineered wood, engineering, design, and building industries for all of North America and Australia.

Building with the most recent cutting edge development tools, CSD® offers solutions for our industry leading designers, drafters, engineers, and builders.

Website: csdsoftware.com/csd/software/

DRAW

- Multiple input styles for quick and easy drawing
- Real Time 3D feedback
- Create realistic model the way it will be built
- Draw the way you want. iStruct® will follow
- Robust graphics tools allow custom detailing in the model

DESIGN

- Analyze anytime for quick results and guidance
- Precision load development for accurate designs
- Solution Seeker finds the optimum product solution
- Easily create required engineering reports
- Automatic load distribution analyzes all components at once

BUILD

- Create Flexible and detailed plot layouts
- Add any type of data to your plot
- Integrate customer details and information
- Create dynamic quotes with exports to point of sale systems
- Send materials to automated saw files or create manual cut lists

ACCESS THE CSD SOFTWARE

Tolko offers authorized customers access to engineered wood design software by CSD. This software includes:



isPlan®

A 3D layout and design solution that allows users to model an entire structure with 2D and 3D views. isPlan® develops and transfers gravity loads through the structure and designs the structural members.



isDesign®

A single member sizing solution that allows users to size floor and roof joists, beams and posts by inputting span and load information. Innovative tools allow selection of the most cost effective solution.



isWall®

The first stand alone wall design application that allows users to model a tall wall and run gravity and wind analysis for all the components of the wall.

To become a Tolko authorized user, please contact your Tolko EWP sales representative at:

Phone: 250-549-5311

Email: EWPsales@tolko.com

**TRUE.
TRUSTED.
TOLKO.**



TOLKO

WWW.TOLKO.COM

Tolko Marketing and Sales
3000 - 28th Street
Vernon, BC V1T 9W9
Tel 250.545.4411 - Fax 250.550.2550